

# SHERCO

MANUEL D'ATELIER | WORKSHOP MANUAL | MANUAL DE TALLER

250 SEF-R  
300 SEF-R



# CONTENTS

<b>FORWARD</b> .....	<b>3</b>
<b>MOTOR TOOLS 250 SEF-R and 300 SEF-R</b> .....	<b>4</b>
<b>TECHNICAL SPECIFICATION</b> .....	<b>5</b>
THE MOTOR .....	5
THE FRAME.....	6
<b>STANDARD ADJUSTMENT</b> .....	<b>7</b>
THE FORK.....	7
SHOCK ABSORBER.....	8
<b>OPERATIONS REQUIRING DEMOUNTING OR NOT ENGINE</b> .....	<b>9</b>
<b>REMOVING/REINSTALLING THE MOTOR</b> .....	<b>10</b>
REMOVING THE MOTOR .....	10
REINSTALLING THE MOTOR.....	10
<b>MOTOR</b> .....	<b>11</b>
REMOVING THE CYLINDER HEAD .....	11
MOTOR TOP END CONTROLS.....	13
<i>Inspection of the cylinder for wear</i> .....	13
<i>Piston / cylinder clearance</i> .....	13
<i>Piston wear</i> .....	14
<i>Ring groove / piston ring</i> .....	14
<i>Ring end gap</i> .....	14
<i>Inspect the connecting rod, the piston pin and the piston for wear</i> .....	14
<i>Check the camshafts for wear</i> .....	15
<i>Checking the camshafts and camshaft journals for wear</i> .....	15
<i>Eccentricity of the camshaft</i> .....	15
<i>Inspect the cylinder head for flatness</i> .....	16
<i>Visually inspect the timing chain for damage</i> .....	16
<i>Inspecter visuellement les patins de distributions</i> .....	16
<i>Valve – Guide clearance</i> .....	16
REASSEMBLING THE TOP END OF THE MOTOR .....	17
<i>Reassemble the piston</i> .....	17
<i>Valve timing</i> .....	19
<i>Checking the valve clearance</i> .....	21
<i>Replacing the cam chain</i> .....	21
DISASSEMBLING THE RIGHT SIDE.....	22
<i>Clutch dismantling</i> .....	22
<i>Inspect the clutch</i> .....	22
<i>Check the clutch spring length</i> .....	22
<i>Reassembly of the clutch</i> .....	22
<i>Disassembling and inspecting the water pump</i> .....	23
<i>Changing the water pump shaft seal requires removing the clutch housing</i> .....	23
<i>Removing the clutch hub and the clutch basket</i> .....	24
<i>Reassembling the clutch hub components</i> .....	24
DISASSEMBLING THE LEFT SIDE .....	25
<i>Disassembling the ignition case</i> .....	25
<i>Replacing the stator and sensor system</i> .....	25

<i>Removing the rotor</i> .....	26
<i>Inspect the freewheel and the needle bearings</i> .....	26
<i>Reassembling the ignition case</i> .....	27
<b>CRANKCASE/TRANSMISSION/CENTRAL CRANKCASES</b> .....	<b>28</b>
<i>Disassembling the transmission and the crankshaft</i> .....	28
<i>Checking the transmission components</i> .....	29
<i>Checking the crankshaft</i> .....	30
<i>Checking the center crankcases</i> .....	31
<i>Reassembling the central crankcase assembly</i> .....	32
<b>TIGHTENING TORQUES</b> .....	<b>35</b>
<b>CLEAN INJECTOR BODY</b> .....	<b>37</b>
<i>Material</i> .....	37
<i>Put down the injector body</i> .....	37
<i>Clean of injector body</i> .....	39
<i>Replace the injector body</i> .....	39
<b>SYNERJECT INJECTION SYSTEM INSTRUCTION MANUAL</b> .....	<b>40</b>
SYNERJECT INJECTION SYSTEM PRESENTATION .....	40
SOFTWARE PRESENTATION.....	46
<b>2.1</b> Connection with Keyless system .....	46
<b>2.2</b> Software setup : configuration menu .....	48
<b>2.3</b> Menu update and synchronization.....	49
USING THE SOFTWARE .....	51
<b>ELECTRICAL INSTALLATION CHECKING</b> .....	<b>64</b>
<b>CONTROLS OF THE SENSORS</b> .....	<b>66</b>
CONTROL TPS SENSOR.....	66
VALUES OF TEMPERATURE SENSOR.....	67
<b>CABLE DIAGRAM</b> .....	<b>68</b>
<i>Injection beam</i> .....	68
<i>250 SEF light system cable diagram</i> .....	71
<i>300 SEF light system cable diagram</i> .....	72
<i>250 SEF-R Racing light system cable diagram</i> .....	73
<i>300 SEF-R Racing light system cable diagram</i> .....	74
<i>Flasher installation cable diagram</i> .....	75
<i>Fan cable diagram</i> .....	76

# FORWARD

This manual is designed primarily for skilled mechanics working in a properly equipped workshop. The execution of the operations in this manual requires a strong mechanical knowledge and specific SHERCO tools designed for the 250 SEF-R and 300 SEF-R engine.

This workshop manual is a supplement to the SHERCO 250 SEF-R and 300 SEF-R owner's manual.

# MOTOR TOOLS 250 SEF-R and 300 SEF-R

TOOL REF	DESIGNATION
1819	Dead point
1814	Clutch holder tool
4753	Ignition tool
2067	Swingarm tool
2068	Freewheel tool
2069	Oil seal tool (Gear box exit)
2070	Oil level gauge tool
2071	Bearing tool 6905 (Gear selector drum)
2072	Bearing tool 6222 (Clutch shaft)
2079	Bearing tool 6203 left (Balancer)
2080	Oil seal tool 8x18x5
1822	Bearing tool (Water pump shaft)
2078	Oil seal 36x57x7,5 right (Crankshaft)
2077	Bearing tool 4905 right (Balancer)
2074	Bearing tool 6003 (Gear shaft)
1968	Oil seal tool (Water pump)
2075	Piston tool
2076	Bearing tool (Crankshaft)
1816	Ring tool
1821	Engine support tool 250
1817	Pinion tool
1818	Piston support
2073	Resort tool
R462	Flywheel puller
R464	Ring extractor
R450	Gear selector oil seal tool
3785	Spark key
6267	Shunt for keyless system

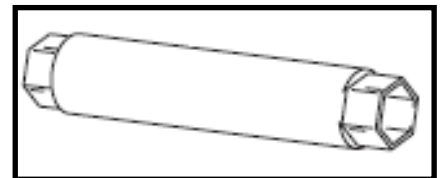
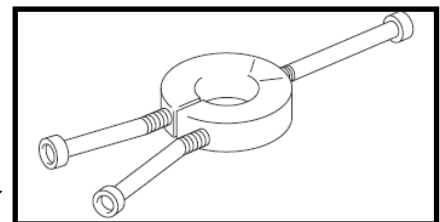
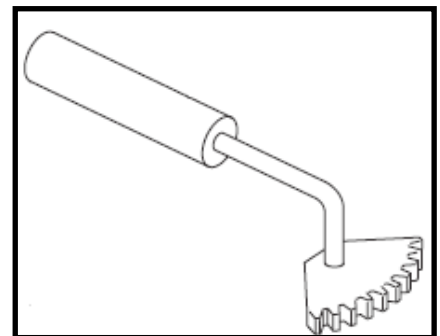
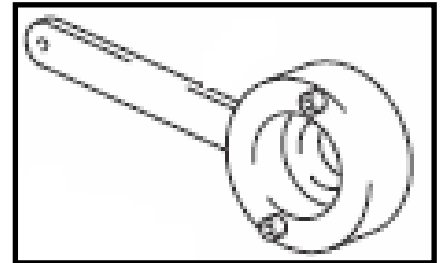
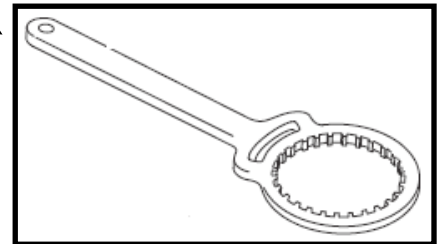
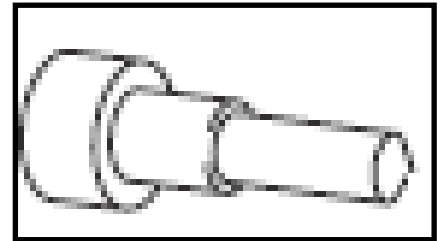

# TECHNICAL SPECIFICATION

## THE MOTOR

	250 SEF-R	300 SEF-R
Type	Liquid cooled single cylinder 4 strokes engine	
Displacement	248.6 CC	303.7 CC
Bore/Stroke	76/54.8mm	84/54.8mm
Compression ratio	13.2 :1	12.85:1
Fuel	Without lead 95 or 98	
Valve timing	4 valves, DOHC driven by tooth type chain	
Admission valve diameter	29mm	30mm
Exhaust admission valve	25mm	
Thickness admission valve	0.15-0.2mm	
Thickness exhaust valve	0.2-0.25mm	
Crankshat bearing	2 roller bearing	
Piston	Aluminium forge	
Lubrification	Lubrication under pressure with 2 trochoidal pumps	
Motor oil	1 litre SAE 10W40	
Primary reduction ratio	21 :70	
Gear box :	6 speed	
1 <sup>st</sup>	14 : 33	
2 <sup>nd</sup>	17 : 30	
3 <sup>rd</sup>	19 : 28	
4 <sup>th</sup>	21 : 26	
5 <sup>th</sup>	23 : 24	
6 <sup>th</sup>	25 : 22	
Final transmission	13 X 49	13 X 48
Clutch	Multi-disk in oil bath. Hydraulic command	
Ignition system / Batterie	Electric start/12V 4Ah	
Electronic injection	Synerject	

# TECHNICAL SPECIFICATION

## THE FRAME

Frame	Semi-perimeter CrMo steel with aluminum subframe
Fork	SACHS USD Gold Series 48mm dia. (standard) & WP USD 48mm dia. (racing)
Rear suspension	WP Suspension with separate cylinder
Travel Front/Rear	300/330mm
Front brake	disc Ø 270mm (standard), Ø 256mm (racing)
Rear brake	disc Ø 220mm
Brake disc	2.7mm front et 3.6mm rear
Front tire	90/90-21"
Rear tire	140/80-18"
Pressure TT	0.9 bar
Fuel tank capacity	9.7l with 1l of reserve
Angle of the steering column	27.3°
Wheel base	1480mm
Weight (without fuel)	102 kg

# STANDARD ADJUSTMENT

## THE FORK

Standard adjustment - Fork Sachs USD Gold Series Ø48MM

Compression	Turn clockwise to the stop, then back of 12 clicks
Rebound	Turn clockwise to the stop, then back off 12 clicks
Spring	4.5N/mm
Fork oil	SAE 5
Oil capacity	600cm <sup>3</sup>
Oil level	130mm

Standard adjustment - Fork WP USD Gold Series Ø48MM

Compression	Comfort	20 clicks back
	Standard	13 clicks back
	Sport	8 clicks back
Rebound	Comfort	18 clicks back
	Standard	13 clicks back
	Sport	10 clicks back
Preload	Comfort	2 turns
	Standard	4 turns
	Sport	6 turns
Spring stiffness	Rider weight : 143 -165 lbs	4.0N/mm
	Rider weight : 165- 187 lbs	4.2 N/mm (original)
	Rider weight : 187- 210 lbs	4.4N/mm
Type of oil		SAE 4
Oil level measurement (fork compressed and spring removed) from the top of the fork tube		110mm



# STANDARD ADJUSTMENT

## SHOCK ABSORBER

Standard adjustment - WP Shock absorber

Low-speed compression	Comfort	20 clicks back
	Standard	15 clicks back
	Sport	12 clicks back
High-speed compression	Comfort	2.5 clicks back
	Standard	2 clicks back
	Sport	1.5 clicks back
Rebound	Comfort	15 clicks back
	Standard	13 clics en arrière
	Sport	11 clics en arrière
Spring stiffness	Rider weight : 143 -165 lbs	48N/mm
	Rider weight : 165- 187 lbs	51N/mm (origine)
	Rider weight : 187- 210 lbs	54N/mm

## OPERATIONS REQUIRING DEMOUNTING OR NOT ENGINE

	Removing engine	Not demounting engine
Crankshaft	•	
Gear box	•	
Crankshaft bearing	•	
Gear Box bearing	•	
Piston		•
Cylinder		•
Cylinder head		•
Valve timing		•
Ignition		•
Pinion of ignition system		•
Freewheel		•
Clutch		•
Water pump		•
Oil pump		•
Gear selection		•

# REMOVING / REINSTALLING THE MOTOR

## REMOVING THE MOTOR

---

### ATTENTION

*To remove the engine, you must remove the swing arm axle, the swing arm and the rear wheel. To keep the bike from falling, remember to support the chassis with an appropriate jack.*

- Drain (refer to the owner's manual)
  - the engine oil
  - the engine coolant
- Remove the seat.
- Disconnect the battery.
- Remove the fuel tank and its covers.
- Disconnect all the electrical wiring connectors from the engine. (Starter, TPS sensor, water temperature sensor, coil, fuel injector).
- Remove the exhaust.
- Remove the ignition coil.
- Remove the fuel injector body.
- Remove the chain.
- Remove the chain guard.
- Remove the clutch actuating cylinder.

### ATTENTION

*When the clutch actuating cylinder is removed the piston is loose. Hold the piston in place using a plastic strap.*

- Remove all of the water hoses connected to the motor.
- Remove the left radiator.
- Loosen all of the engine bolts [A].
- Loosen the swing arm bolt.
- Remove the brackets that attach the cylinder head to the chassis.
- Remove the motor mounting bolts.
- Remove the swing arm bolt.
- Remove the motor.

## REINSTALLING THE MOTOR

---

The motor should be reinstalled in the frame in the reverse order of how it was removed. The following torque values should be utilized.

### Tightening torques:

**Motor mounting bolts: 60Nm**

**Swing arm axle nut: 100 Nm**

**Clutch receiver screws: 10 Nm**

**Cylinder head bracket bolts: 23Nm**

**Exhaust mounting bolts: 10Nm**

# MOTOR

For additional details refer to the parts catalog 250 SEF-R \_ 300 SEF-R

## REMOVING THE CYLINDER HEAD

- Remove the spark plug.
- Remove the valve cover.
- Remove the three valve cover screws.

*ATTENTION : These three screws are equipped with o-rings ref: 0900.*

- Remove the cap from the ignition cover [A].

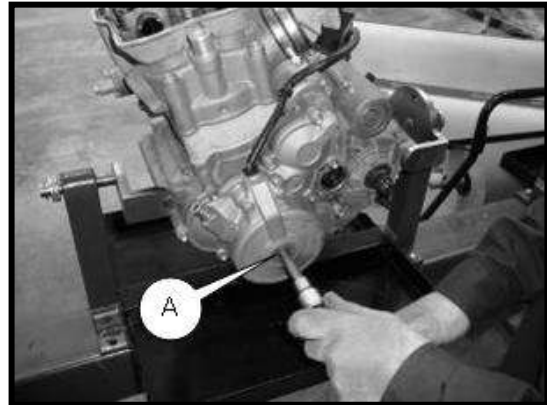

- Remove the timing control plug [A]

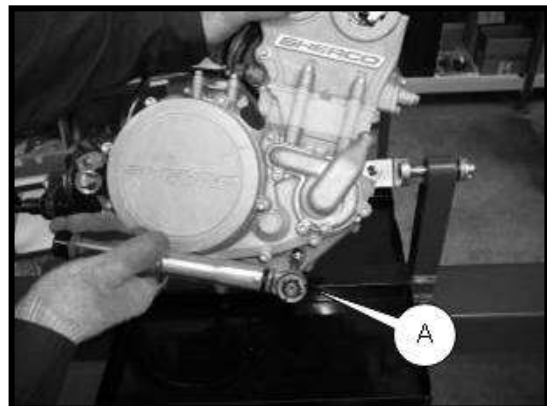

- Turn the engine counterclockwise in order to align the timing marks on the crankshaft with the marks on the timing gear. Install the special tool that locks the engine at Top Dead Center [A] (ref 1819)

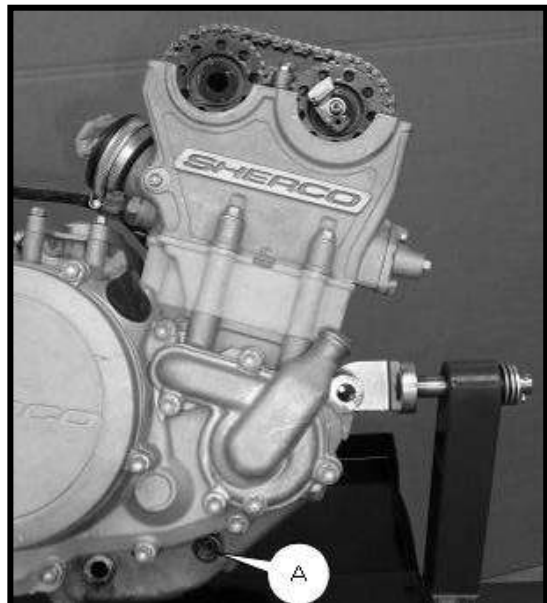

- Remove the screws from the cam chain tensioner as shown in the photo.
- Remove the cam chain tensioner.
- Remove the spark plug well.

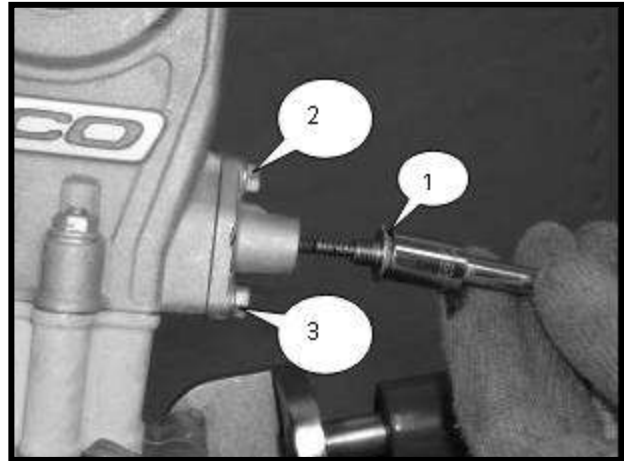

- Remove the camshaft bearing journal. Starting on the inside, remove the screws in a criss cross manner (see the numbers on the photo).

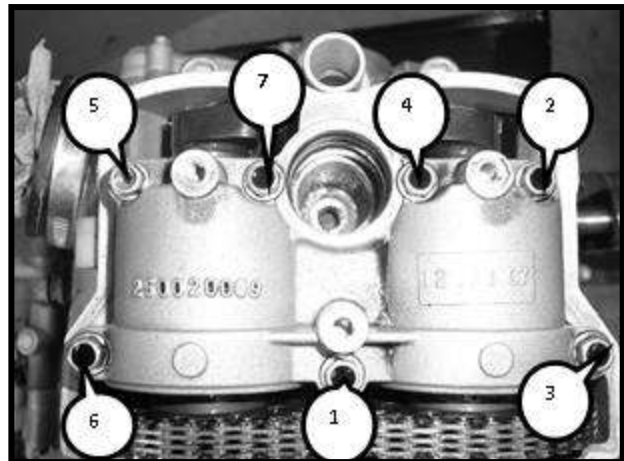

- Remove the exhaust camshaft retaining clip.
- Remove the exhaust camshaft.
- Remove the intake camshaft retaining clip.
- Remove the intake camshaft.

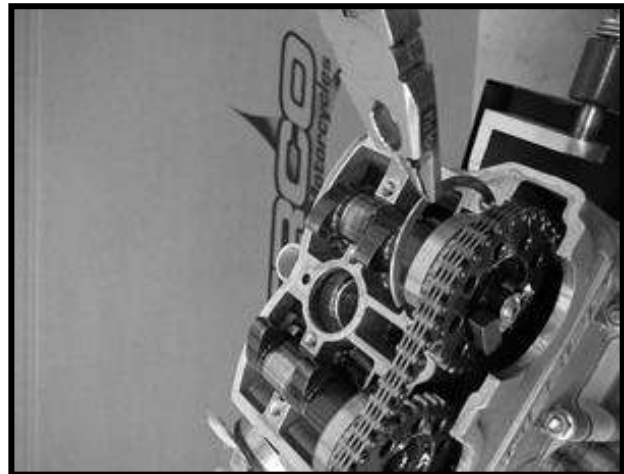

- Remove the two nuts M6 and the washer.

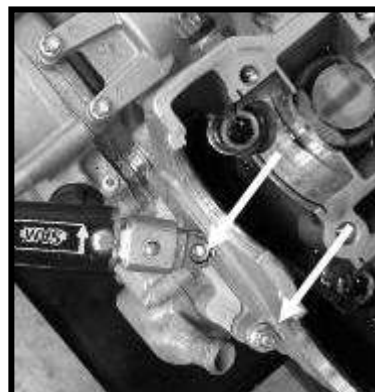

- Remove the cylinder head bolts (Be sure to loosen them in the correct direction).

**ATTENTION:** Black bolt N°1 on the picture is longer, 3 bolts are identical.

- Remove the cylinder head.
- Remove the head gasket and the cylinder.

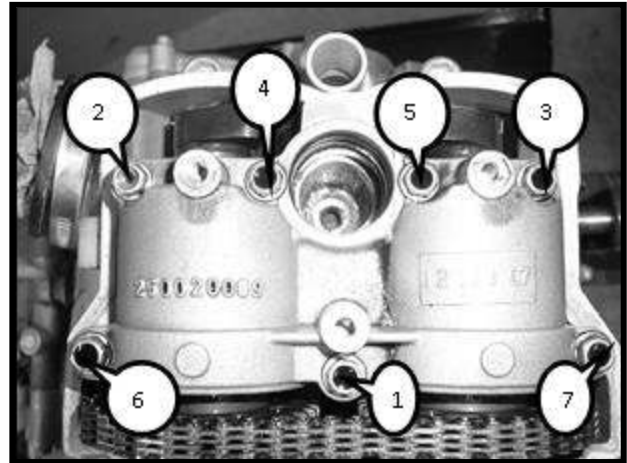

## MOTOR TOP END CONTROLS

### Inspection of the cylinder for wear

Measure the inside diameter of the cylinder when it is cold.

Inspect the inside of the cylinder for any scratches or other evidence of abnormal wear. If the cylinder is badly damaged or worn it should be replaced.

Since the cylinder does not wear in a uniform manner measure in from side to side and up and down as shown.

If the inside measurement of the cylinder exceeds the tolerance limit it must be replaced.

**(A)=10 mm**

**(B)=25 mm**

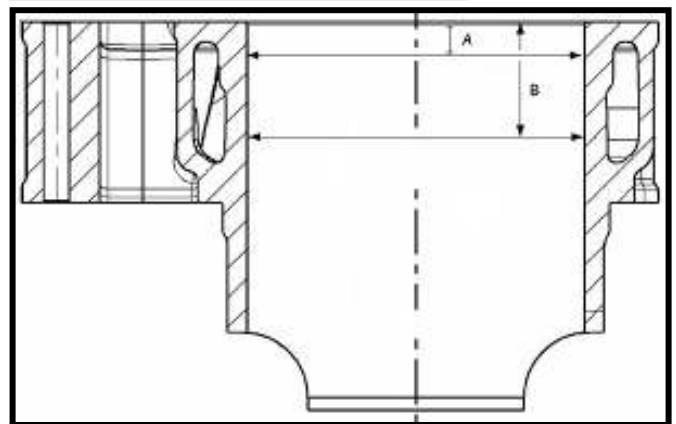
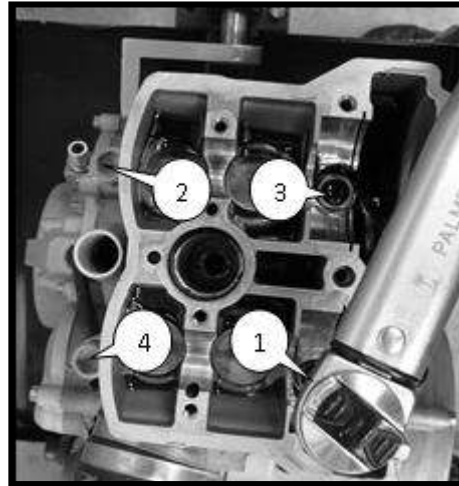

### Piston / cylinder clearance

To determine the piston / cylinder clearance as accurately as possible it is sufficient to measure the piston and the cylinder, and then calculate the difference between the two values. Measure the diameters as shown.

**Piston / cylinder clearances**

**Standard 0.03 – 0.05 mm**

**Limit 0.10 mm**

	250 SEF-R	300 SEF-R
Cylinder diameter (A)	75.982±0.01 mm	83.982±0.01 mm
Cylinder diameter (B)	75.982~75.995 mm	83.982~83.995 mm
Taper limit	0.05 mm	0.05 mm
Out of round limit	0.05 mm	0.05 mm

### Piston wear

- Using a micrometer measure the outside diameter of the piston [A] 10mm [B] above the bottom of the piston and at right angles to the axis of the piston.

If the outer diameter of the piston is below the tolerance it must be replaced.

**Piston 250 SEF-R= 75.950±0.005 mm**

**Piston 300 SEF-R= 83.950±0.005 mm**

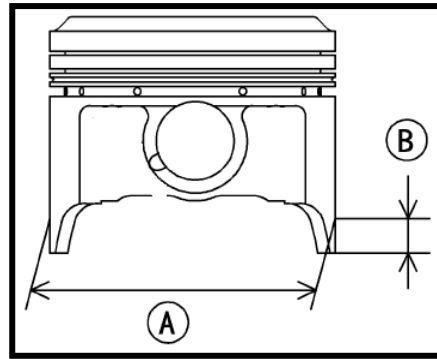

### Ring groove / piston ring

- Using a feeler gauge measure the clearance between the piston ring and the ring groove.
- Check in several places to determine the actual clearance if the clearance is greater than the maximum, replace the piston ring and if necessary the piston.

#### **Ring groove / piston ring**

##### **Standard**

**Compression ring: 0.030-0.065 mm**

**Limit 0.13 mm**

**Oil control ring: 0.020-0.055 mm**

**Limit 0.13 mm**

### Ring end gap

**Compression ring : 0.3-0.4 Limit 0.7 mm**

**Oil control ring : 0.3-0.5 mm**

### Inspect the connecting rod, the piston pin and the piston for wear

- Visually inspect the circlips in place. If they appear worn or distorted replace them. If the hole for the circlips appears worn replace the piston.
- Measure the piston pin with a micrometer. If at any place on the pin the diameter is below the limit replace the piston pin.
- Measure the diameter of the piston pin holes in the piston and the hole in the connecting rod. If the one or more holes in the piston are incorrect replace the piston. If the diameter of the hole in the connecting rod is incorrect, replace the connecting rod.

**Piston pin diameter**

**15.997-16.000 mm**

**Piston pin hole diameter in the piston**

**16.004-16.009 mm**

**Connecting rod hole diameter**

**16.000-16.011 mm**

### Check the camshafts for wear

- Remove the camshafts.
- Measure the heights [A] of the camshaft lobes with a micrometer.  
If the cams are worn beyond the limits, replace the cams.

**Camshaft height limit 250**

**Exhaust: 31.245 mm**

**Intake: 32.145 mm**

**Camshaft height limit 300**

**Exhaust: 31.977 mm**

**Intake: 32.145 mm**

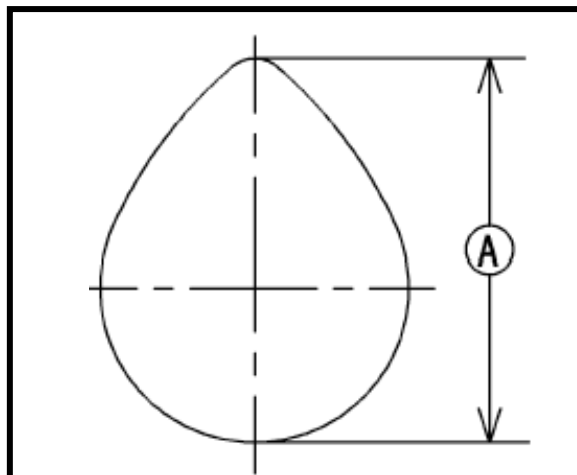

### Checking the camshafts and camshaft journals for wear

- Measure the clearance between the camshaft and the camshaft journals using plastigage [A].
- Lubricate the fixing bolts with engine oil and tighten to the proper torque.

**Tightening torque**

**Camshaft journal mounting bolts: 10 Nm**

If any of the measurements are over the limit, then measure the diameter of each journal.

**Camshaft / journal clearance**

**Standard: 0.020 – 0.062 mm**

**Limit: 0.15 mm**

If the diameter of the journal is below the limit replace the camshaft and measure again.

**Camshaft journal diameter**

**Standard: 23.05 – 23.25 mm**

**Limit 23.02 mm**

If the clearance is outside of the tolerance limits, replace the entire cylinder head.

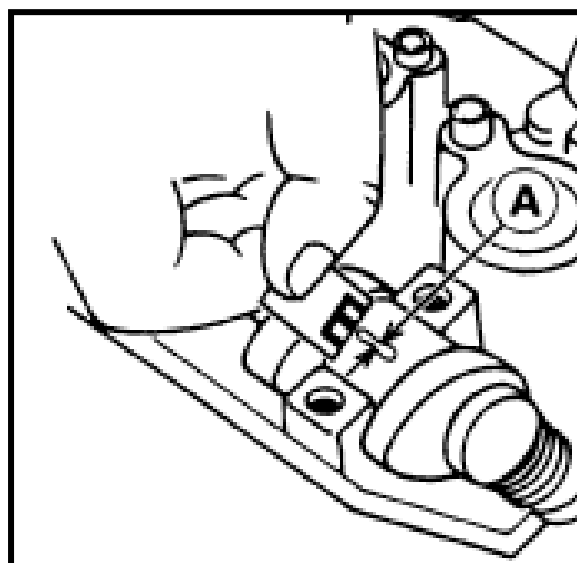

### Eccentricity of the camshaft

- Measure the camshaft runout.  
If it is out of tolerance, replace the camshaft.  
**Runout : Less than 0.03 mm**

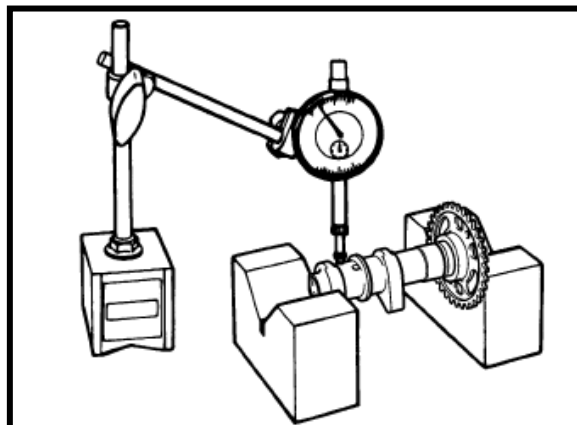



### Inspect the cylinder head for flatness

- Place the cylinder head on the workbench
- Using a precision straight edge [A] and a feeler gauge check the head for warpage; check in several places as shown in the photo.

If the warpage is above the limit, repair if possible. If the damage is severe replace the head.

**Cylinder head warpage:  
Limit = 0.05 mm**

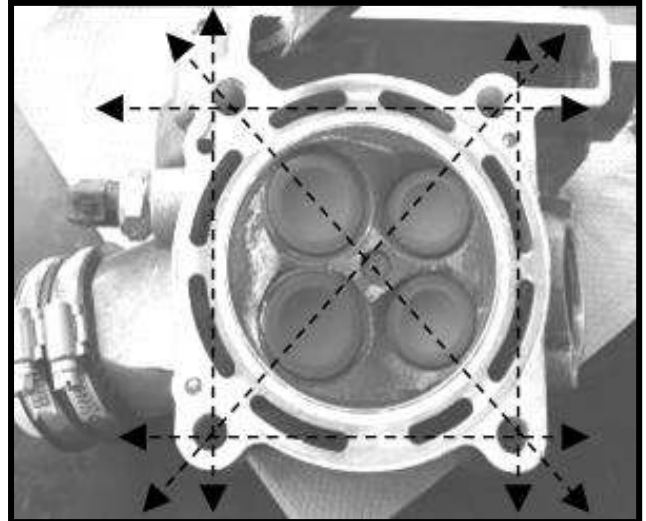

### Visually inspect the timing chain for damage

- Inspect the timing chain by flexing it to determine if there are any tight spots. If tight spots are found it should be replaced.
- Check the automatic chain adjuster and make sure that it is not in the last ratchet notch.

### Inspecter visuellement les patins de distributions

- Visually inspect all of the cam chain tensioner channel guides and pads including the ones on the cylinder head cover.
- Change as necessary.

### Valve – Guide clearance

Intake :

**Mini clearance : 0.02 mm  
Maxi clearance : 0.045 mm**

Escape :

**Mini clearance : 0.04 mm  
Maxi clearance : 0.065 mm**

# REASSEMBLING THE TOP END OF THE MOTOR

## Reassemble the piston

- Install the piston rings on the piston with the end gaps as shown in the photo, the compression ring goes in the top groove and the oil control ring goes in the bottom groove.

- A Lower expander end gap
- B Lower piston ring end gap
- C Upper expander end gap
- D Upper piston ring gap

*ATTENTION : The expander rings do not have a top or bottom; however the oil control ring and the compression ring must be installed with the « N » mark facing up.*

- Apply engine oil to the wrist pin internal bore in the piston.
- Carefully note the piston orientation (the small cut outs are on the exhaust side)
- Install the locating pins [B].
- Install the base gasket [C].
- Use special tool number 1821 to maintain the piston in the correct location [A].

*ATTENTION : Use the same head gasket (thickness 0.3 or 0.4mm depending on the model).*

- Place one of the cir clips in the special tool number 2075 as shown in the photo; install the clip close to one end of the tool.
- Use the tool to set up the clip for installation on the wrist pin. Install the circlip on the wrist pin.

- Mettre le poussoir de l'outil pour mettre en place le clip.
- Mettre l'axe de piston.

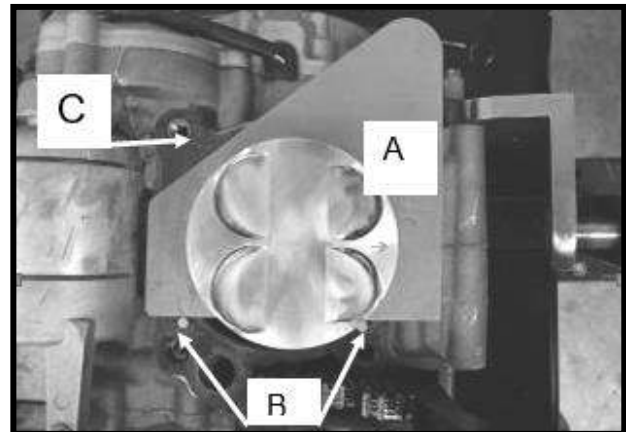
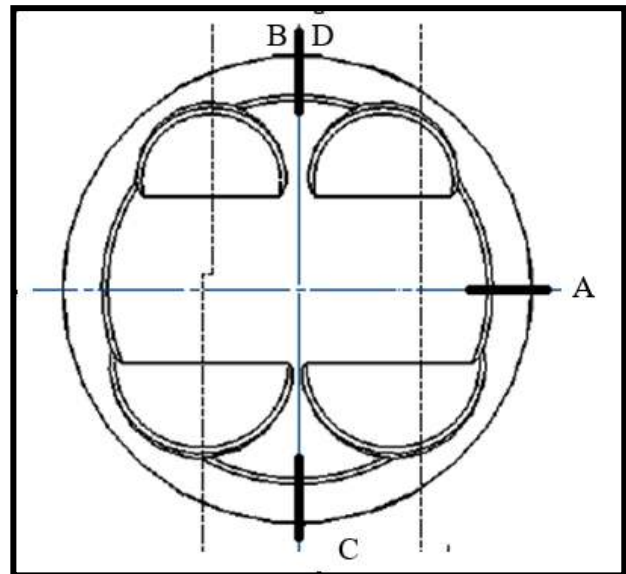

- Install the wrist pin into the piston and connecting rod using the tool and lightly tapping with a hammer.
- Install the opposite circlip, using the special tool.
- Install the cylinder over the piston using an appropriate ring compressor.



- Install the two cylinder head locating pins [A].
- Install the head gasket [B].
- Install the cylinder head.

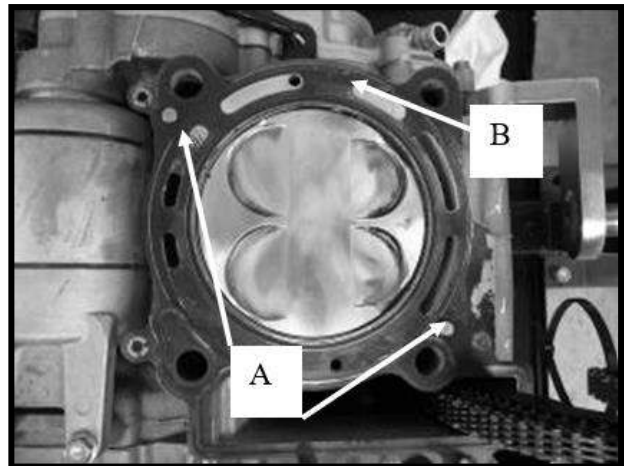

- Install the head bolts noting the different lengths; tighten them using two passes in the order shown in the photo.
- Install and tighten the two M6 nuts.

**Cylinder head torque:**

**Studs 1<sup>st</sup> pass: 30 Nm**

**2<sup>nd</sup> pass: 45 Nm**

**Nuts M6: 10 Nm**

*ATTENTION : The two internal bolts are of different length and are equipped with washers.*

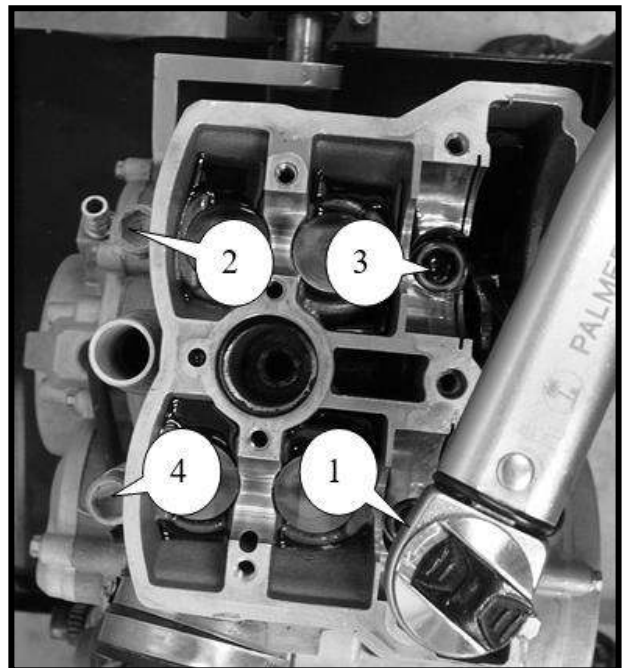

## Valve timing

- Verify that tool number 1819 is still properly installed.
- Install the intake cam.
- Install the exhaust cam.  
(see the photo for how to set the timing marks)

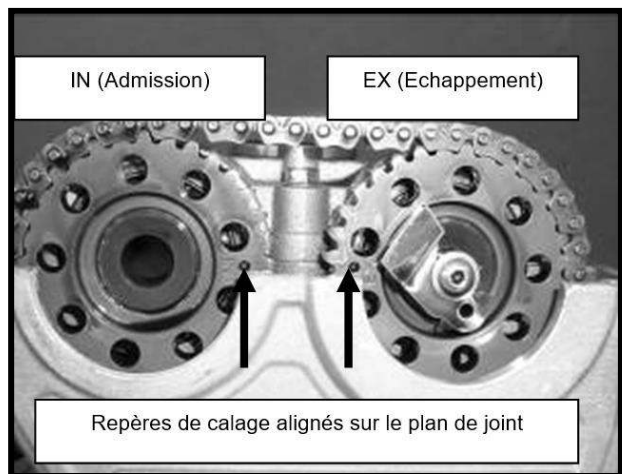
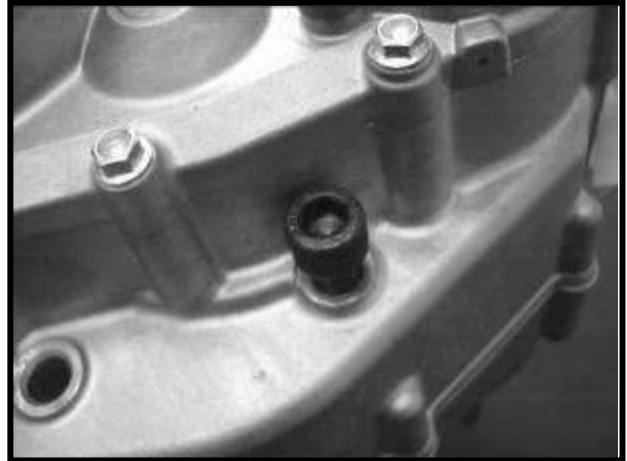

- Install the camshaft retaining clips.
- Apply moly disulfide grease to the camshafts.

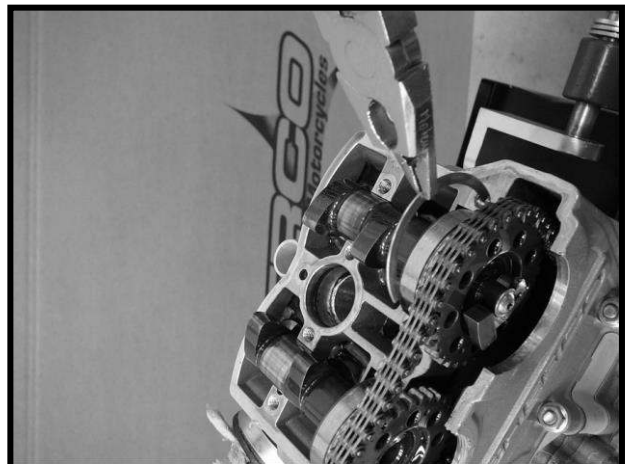

- Install the camshaft retaining cover. (pay careful attention to the tightening order).  
**Camshaft retaining cover torque**  
**10Nm**

*ATTENTION : The screw n°1 is a M6 X 35*

- Install the camshaft chain tensioner using a new gasket.  
**Torque the two fixing bolts to:**  
**10Nm**
- Install the cam tensioner adjusting bolt (pay attention to the o-ring).  
**Torque the tensioner adjusting screw to: 10Nm**
- Remove the special tool number 1819.
- Rotate the engine a few times to make sure that the valve timing is correct.
- Finally check the valve timing using the timing marks.
- Replace the cap that was removed to install tool number 1819.  
**Torque the cap to:**  
**8Nm**
- Replace the spark plug well.

*ATTENTION : Make sure that the o-rings are installed on the spark plug well.*

- Apply a thin coat of silicone to the camshaft end cap bores.
- Replace the valve cover.
- Install the valve cover installation bolts.  
**Torque the bolts to:**  
**8Nm**

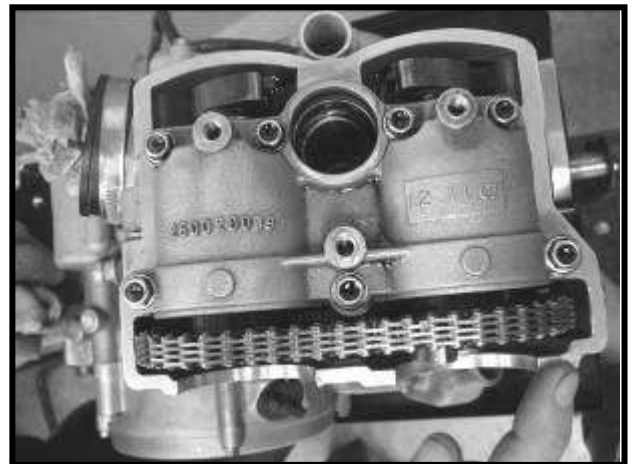
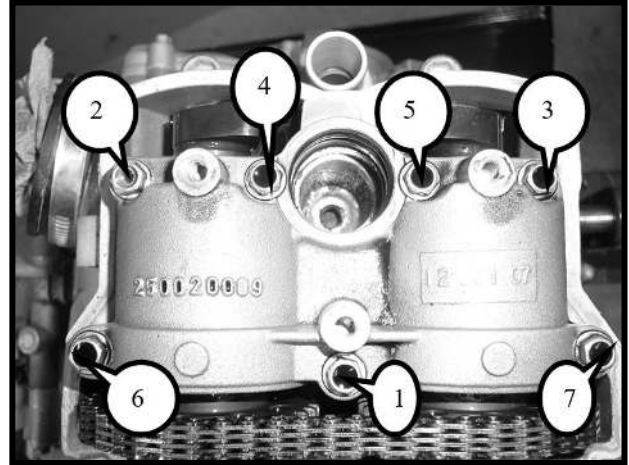

## Checking the valve clearance

- The valve clearance must be checked when the engine is cold.
- Remove the spark plug and the valve cover.
- Remove the timing plug from the crankcase.
- Install special tool number 1819.
- With a feeler gauge measure the clearance between the bucket and the cam.

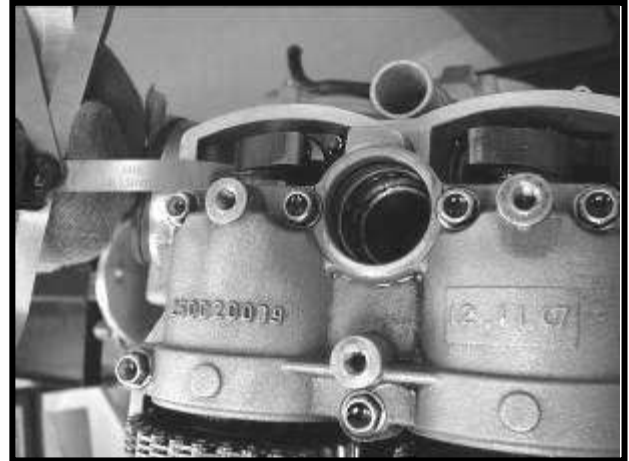

### **Valve clearance**

**Intake 0.15 – 0.20 mm**

**Exhaust 0.20 – 0.25 mm**

- If the clearance is not correct then change the discs in order to obtain the correct gap.
- Remove the discs with a magnet.
- Measure the thickness of the disc and replace with one of the correct thickness.  
**Select the appropriate disc from the existing parts catalog.**

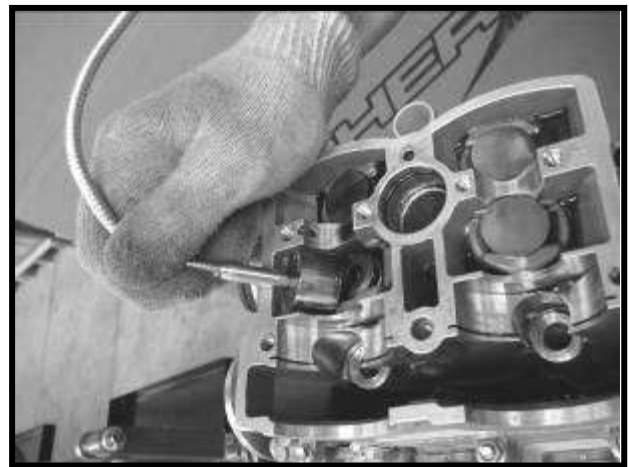

## Replacing the cam chain

- Remove the camshafts (see the chapter on the motor top end).
- Remove the clutch cover (see the chapter on « Right side » removing the clutch).
- Remove the chain tensioner adjuster.
- Remove the cam chain.
- Inspect the cam chain (see « visually inspecting the cam chain »).
- Install the cam chain in the opposite manner in which it was removed.
- Reinstall the cam tensioner bolt and tighten to the correct torque.

**Torque the cam tensioner bolt to:  
10Nm.**

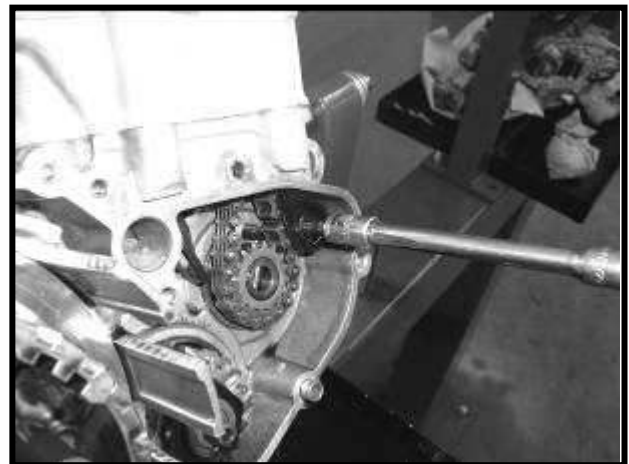

## DISASSEMBLING THE RIGHT SIDE

For additional details see the parts catalog 250 SEF-R and 300 SEF-R.

### Clutch dismantling

- Install special tool number 1819.

*ATTENTION: Only use this tool for disassembling the clutch, do not use it to remove the hub fixing nut.*

- Remove the 4 screws that retain the clutch cover.
- Remove the 5 pressure plate screws (see the photo).
- Sort the discs and make sure they are trimmed and smooth.  
Make sure that the clutch hub rotates freely.

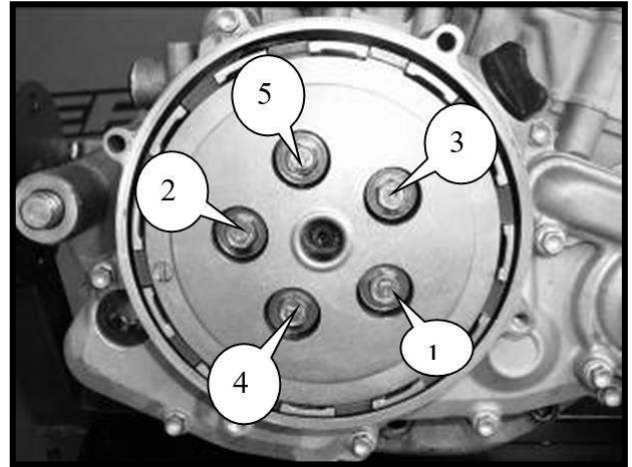

### Inspect the clutch

- Inspect the discs to make sure they are trimmed and smooth.

#### **Friction plate thickness**

**Standard: 2.95**

**Limit: 2.7**

**Deformation limit: 0.3mm**

#### **Steel disc thickness**

**Standard: 1.4**

**Limit: 1.3**

**Deformation limit: 0.3mm**

### Check the clutch spring length

- Measure the free length of the clutch springs.  
**Standard : 37.29mm**  
**Limit : 36.5mm**

### Reassembly of the clutch

- Soak the friction discs in engine oil.
- Replace the discs on the hub by starting with a friction disc and then a steel disc ending with a friction disc.
- Replace the pressure plate.
- Install the 5 springs.
- Install the 5 screws and tighten in an alternating order (see the disassembly photo).

#### **Torque the screws to:**

**10Nm**

- Reinstall the clutch cover, inspect the o-ring and replace if it is damaged.

### Disassembling and inspecting the water pump

- Drain the coolant by removing screw [A].
- Remove the screws from the water pump housing.
- Remove the water pump impeller using a 10 mm socket.

*ATTENTION : If the seal is leaking, coolant will come out of the weep hole (see photo). In order to change the seal the clutch housing must be removed.*

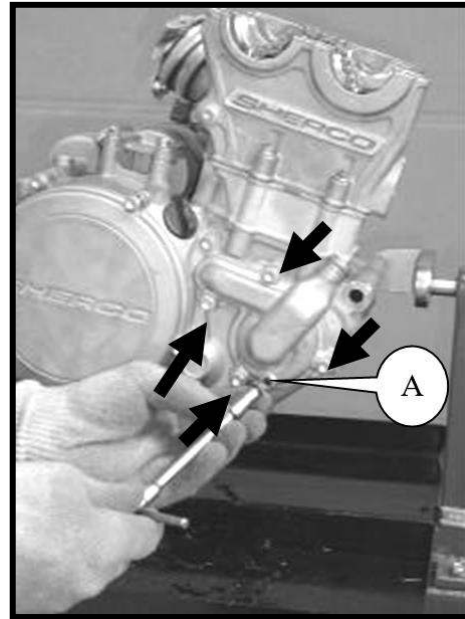

### Changing the water pump shaft seal requires removing the clutch housing

- Remove the clutch housing.
- Remove the clip from the water pump shaft.
- Remove the water pump shaft.
- Remove the roll pin.
- Heat the clutch case in an oven to 70°.
- Extract the bearing.
- Put some grease like “molikote Dx” on the lips of the oil seal.
- Change the seal using special tool number 1968.

*ATTENTION : make sure the seal is installed properly, you should see the spring when you look at the seal. (see photo).*

- Check the bearing, if it requires changing use special tool number 1822.
- Reinstall the parts in the reverse order of their removal. Pay careful attention to the clutch housing locating pins, always install a new paper gasket and if necessary install a new o-ring seal on the water pump housing.

**Tighten the water pump housing screws to:**

**10Nm.**

**Tighten the coolant drain plug to:**

**6Nm.**

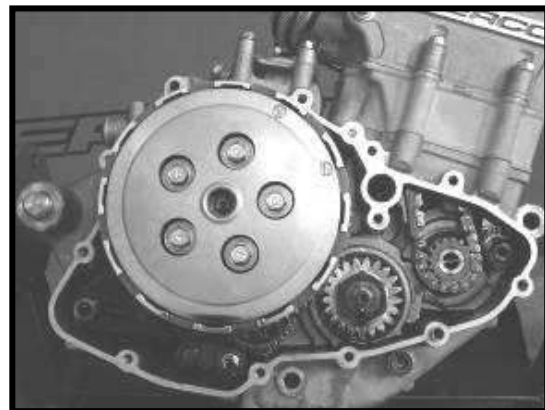
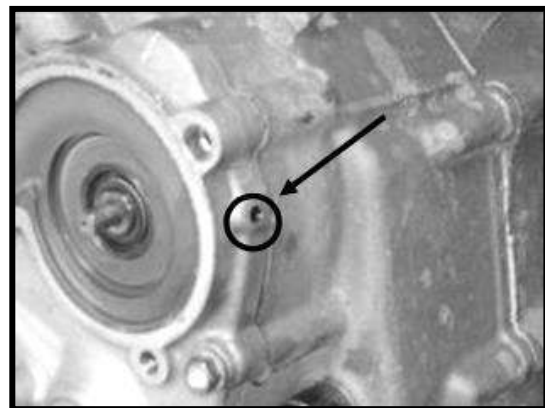



## Removing the clutch hub and the clutch basket

- Drain the engine oil and the engine coolant.
- Remove the clutch housing. (see disassembling the right side paragraph)
- Remove the clutch. (see clutch removal paragraph)
- Remove the clutch release bearing assembly.
- Retain the clutch hub using tool 1814.
- Loosen the clutch hub nut.

*ATTENTION : make sure the special timing tool number 1819 is not installed, if it is, severe damage could occur to the crankshaft and crankcase.*

- Remove the hub and the nut.
- Inspect the needle bearings and replace if necessary.
- Visually inspect the hub and the housing.

## Reassembling the clutch hub components

- Install the thrust washer.
- Install the needle bearings.
- Install the clutch housing.

*ATTENTION : The clutch basket wheel is appeared with the primary gear.*

- Install the spacer washer.
- Install the clutch hub.
- Install the special washer.
- Grease the threads of the shaft and the nut.
- Apply thread locker (blue) to the nut thread.
- Install the fixing nut

**Torque the fixing nut to: 80Nm.**

- Check for free rotation of the clutch hub.
- Blend the special washer over the nut.
- Install the seat, judder spring.

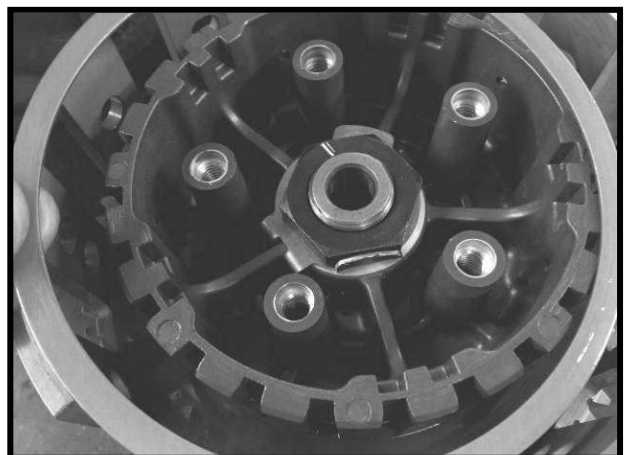
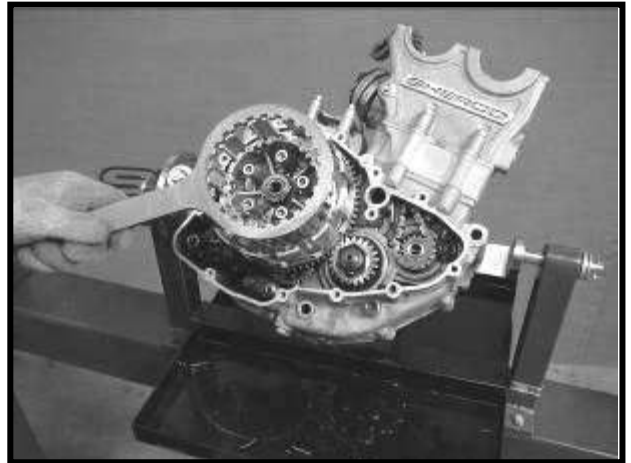
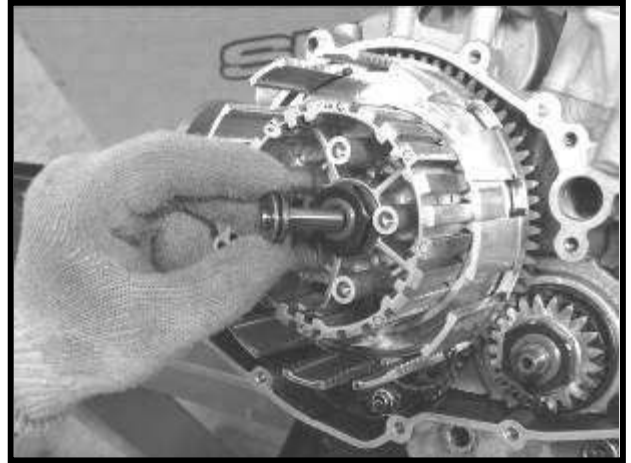

- Install the judder spring

**ATTENTION :** There is a sense.

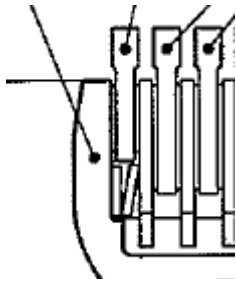

- Install the special friction disc.
- Install all the metal and friction discs.
- Reinstall the clutch release bearing assembly, the clutch spring holder in the reverse order of their removal.

**Torque the clutch screws to: 10Nm**

- Install the clutch cover dowels, a new clutch cover gasket and tighten to 10Nm.

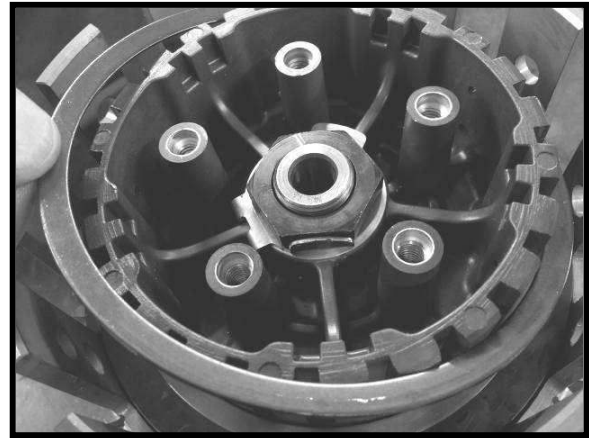

## **DISASSEMBLING THE LEFT SIDE**

For additional details refer to the parts catalog 250 SEF-R and 300 SEF-R.

### Disassembling the ignition case

- Drain the engine oil.
- Remove the 10 screws that retain the ignition case.
- Visually inspect the inner surfaces of the rotor [A] and the outer surfaces of the stator [B].
- Check the pulse generator (sensor)
- Replace if necessary.

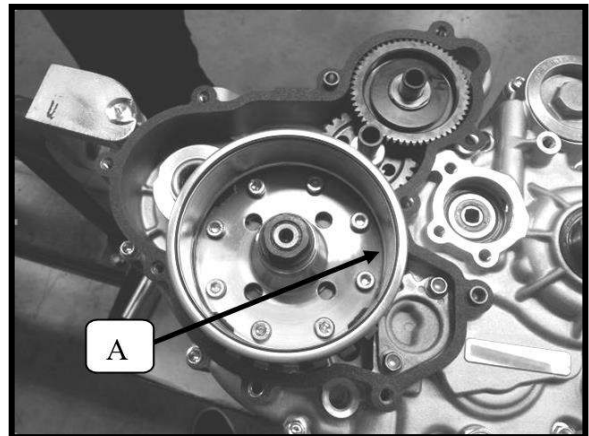

### Replacing the stator and sensor system

- Remove the 2 screws that retain the sensor [C] and the 2 screws that retain the stator [D].
- Install the new parts.
- Reinstall the screws using the proper torque with strong Loctite (red)
- Do not forget the AET washers below the stator screws.
- **Torque the stator and sensor screws to: 8Nm.**

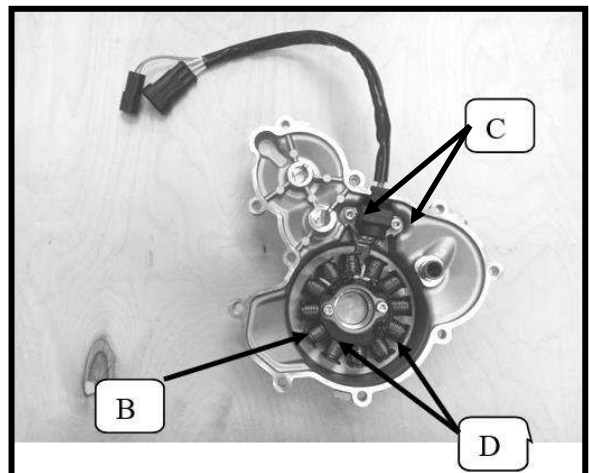

## Removing the rotor

- Utilize the special rotor holding tool number 4753.
- Remove the rotor fixing nut.
- Remove the flywheel using special tool number R462.
- Remove the two starter shafts along with the starter gears.
- Remove the oil centrifuge (anti blowby).

*ATTENTION : the threads this screw are LH, do not turn the wrong direction*

- Remove the freewheel gear.



## Inspect the freewheel and the needle bearings

- Visually inspect the caged needle bearings.
- Replace if necessary.
- Inspect the track of the freewheel gear.
- Replace the freewheel gear if necessary.
- Dismount the free wheel from the rotor by loosening the 8 M5 screws.
- Inspect the free wheel housing.
- Replace if necessary.
- Finally check the rollers on the freewheel.
- Replace if necessary.

*ATTENTION : If the freewheel must be replaced then the rest of the gears must be replaced and vice versa.*

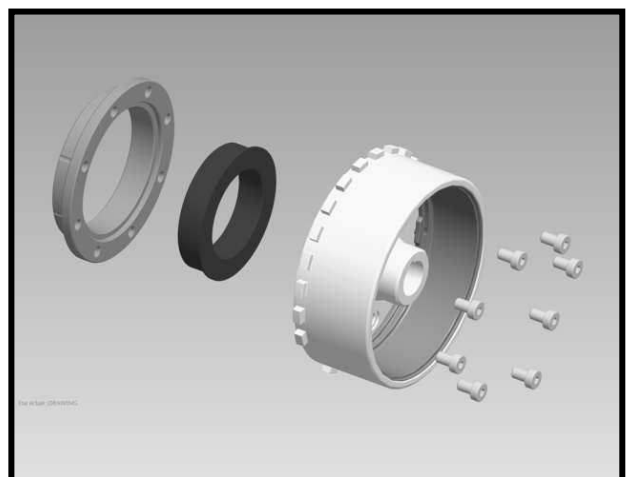
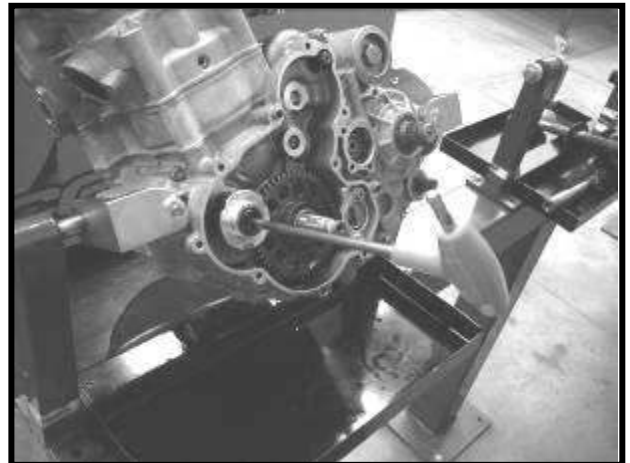

## Reassembling the ignition case

- Install the free wheel gear.
- Reinstall the two starter shafts and their gears.
- Visually inspect the oil seal on the oil centrifuge.
- Use special tool number 1818 to screw the oil centrifuge.  
Apply thread locker (blue) to the oil centrifuge thread.

*ATTENTION : This screw thread is reversed, it is a LH thread.*

- Screw and tighten the centrifuge.  
**Torque the centrifuge fixing screw to: 8 Nm.**
- Inspect the rotor key, change if necessary.
- Pre assembly the rotor group
- Assembly the free wheel in its housing.  
Tighten this set to the rotor with the 8 M5 screws (apply thread locker blue on the screws).
- **Torque the M5 screw to: 8 Nm.**
- Install the rotor (turn the rotor counter clockwise to help facilitate the installation of the lighting rotor).
- Apply proper tightening torque to the nut on the rotor with strong thread locker.
- Install the conical washer.
- Using special tool number 4753 to hold the rotor tighten the fixing nut.

**Torque the fixing clutch nut to 80 Nm with thread locker (blue).**

*ATTENTION : Check the clearance between the rotor and the oil centrifuge.*

- Install the remaining shafts and gears.
- Install the two case locating pins.
- Install a new gasket.
- Install the ignition crankcase cover and tighten the 10 screws.

**Torque the ignition crankcase cover screws to: 10 Nm.**

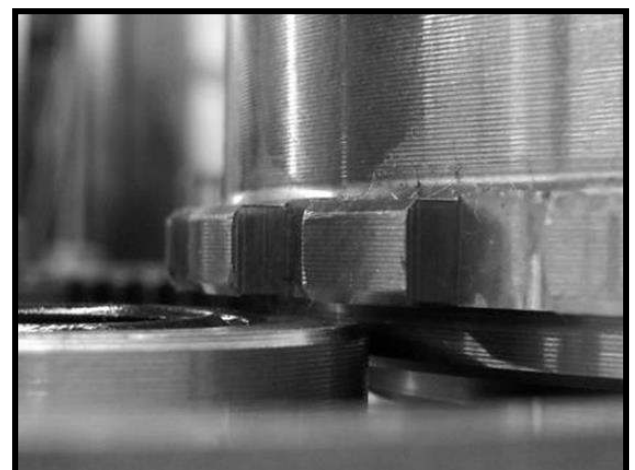
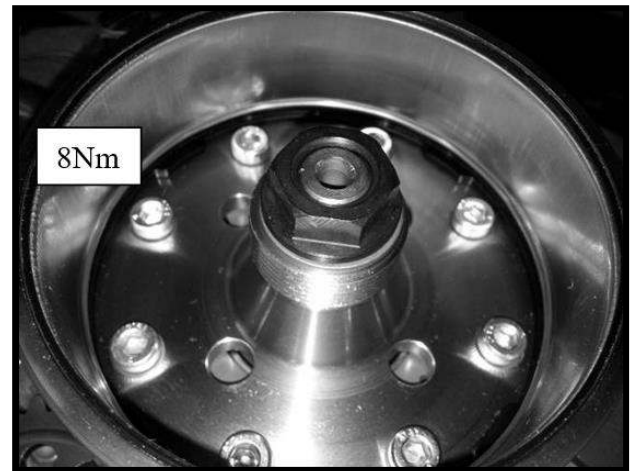

## CRANKCASE / TRANSMISSION / CENTRAL CRANKCASES

### Disassembling the transmission and the crankshaft

- Remove the engine from the frame (see the engine removal chapter).
- Remove the top end (see the top end chapter).
- Remove the ignition components (see the ignition chapter).
- Remove the clutch components (see the clutch chapter).
- Remove the cam drive chain (see the top end chapter).
- Remove the cam chain tensioner and guides.
- Block the transmission primary gear with special tool number 1817.
- Loosen the fixing nut for the counter balancer.
- Remove the counter balancer weight.
- Remove the freewheel / crankshaft spacer using a two-armed gear puller. (see photo)
- Remove the engine oil pump cover.
- Block the transmission primary gear with special tool number 1817.
- Remove the transmission primary gear.
- Remove the clutch basket, the needle bearings and the thrust washer.
- Remove the primary transmission gears.
- Remove the oil pump drive gear.
- Remove the oil pump cover.
- Remove the oil pump rotor.
- Remove the oil pump shaft.
- Remove the gear selector shaft.
- Using special tool number 2073 block the gear selector drum and remove the gear selector index wheel screw...
- Remove the gear selector index wheel.
- Remove special tool number 2073.
- Remove the starter motor.
- Loosen and remove the 13 central crankcase screws.

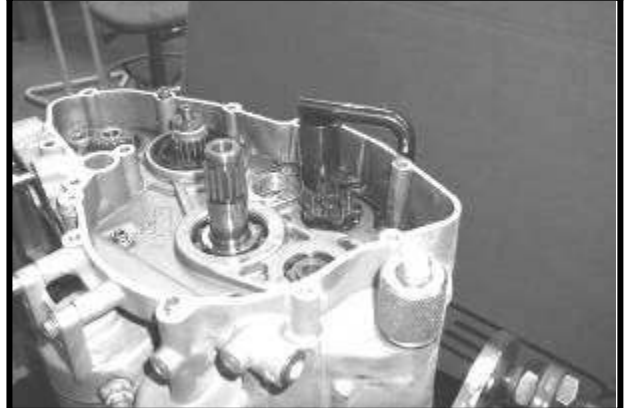
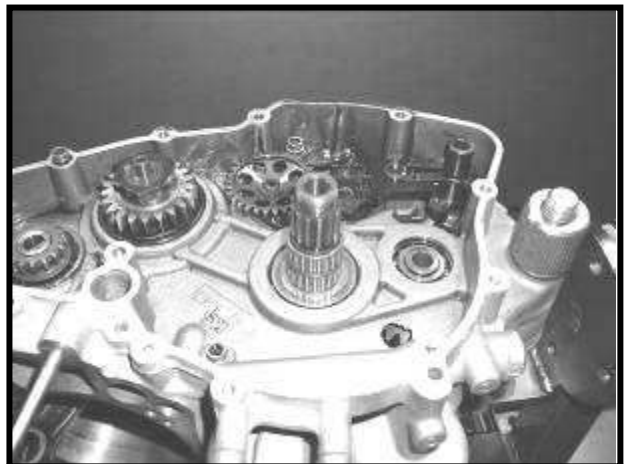
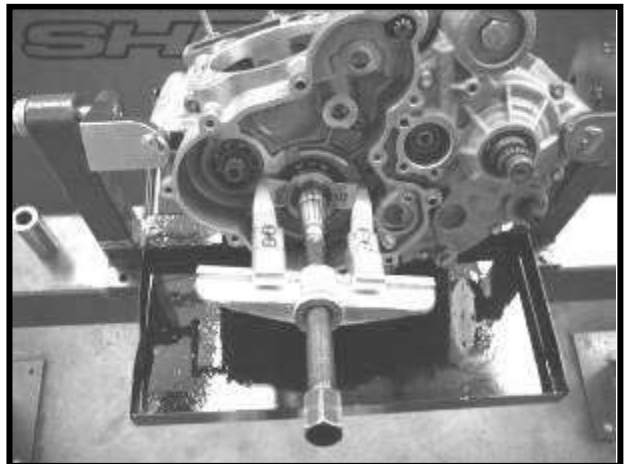
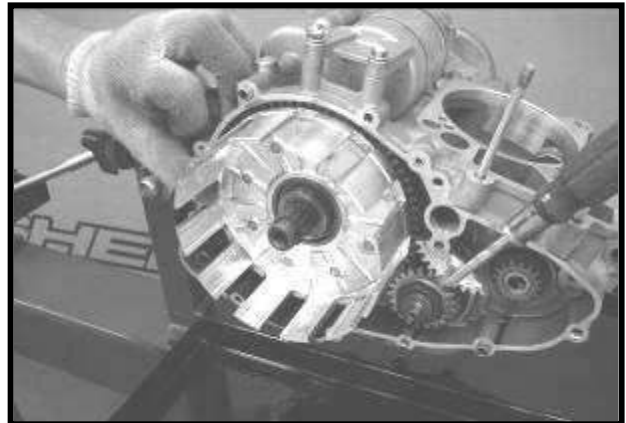

- Remove the Right side crankcase.
- Remove the crankshaft.
- Remove the counter balancer assembly.
- Remove the shifting fork shafts.
- Remove the gear selector drum.
- Remove the shift forks.
- Remove the remaining transmission components.

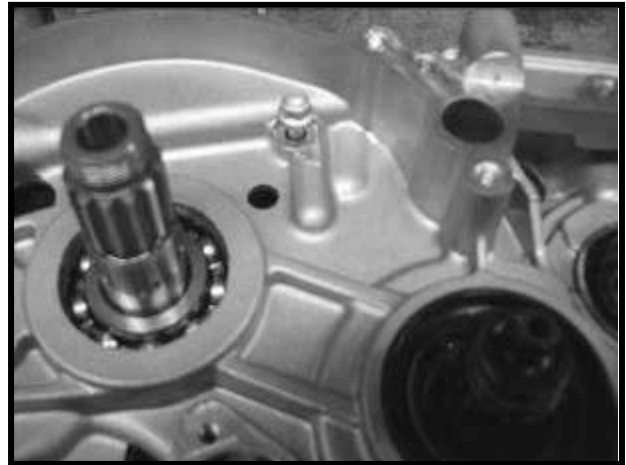

### Checking the transmission components

- Check the condition of all the gears. Inspect the engagement dogs [A], look at all of the gear teeth [B] and the fork shifting groove on each gear [C]. If any of the parts are damaged or badly worn they should be replaced.
- Check the condition of all the shifting forks. Replace the shifting forks if necessary.
- Check the condition of the gear selector drum, make sure it is not deformed, damaged or badly worn. Replace the gear selector drum if necessary.

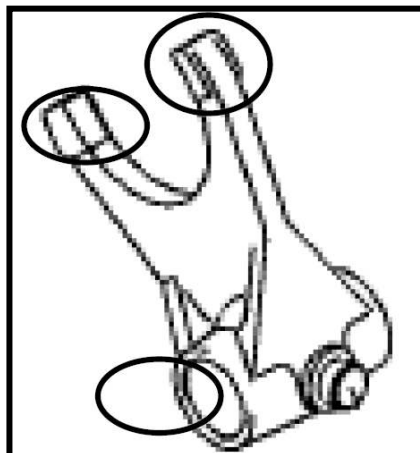
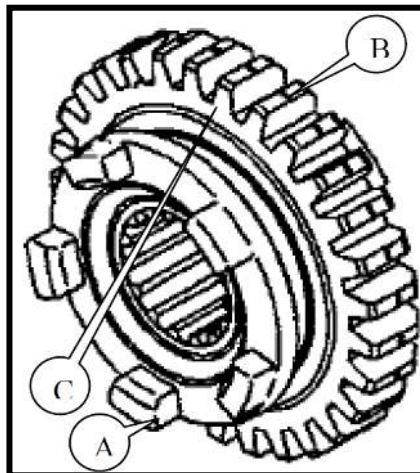

## Checking the crankshaft

### Radial play of the big end bearing :

- Place the crankshaft in a set of V blocks and install a dial indicator as shown [A].
- Push the rod [B] in the direction of the indicator and then push it in the opposite direction. The difference between these two readings is the radial play.

#### **Radial play of the big end bearing:**

**Standard: 0.015 mm – 0.020 mm**

**Tolerance limit: 0.06 mm**

If the radial play exceeds the tolerance limit the crankshaft must be replaced.

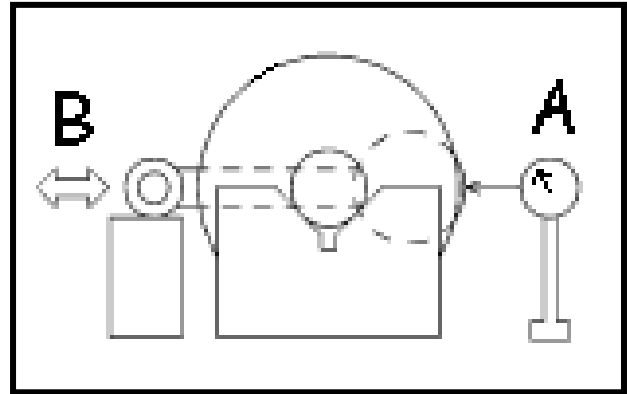

### Lateral movement of the big end :

- Measure the lateral movement of the big end [A].

#### **Lateral movement of the big end:**

**Standard: 0.2 mm - 0.3mm**

**Tolerance limit: 0.55 mm**

If the lateral movement of the big end exceeds the tolerance the crankshaft must be replaced

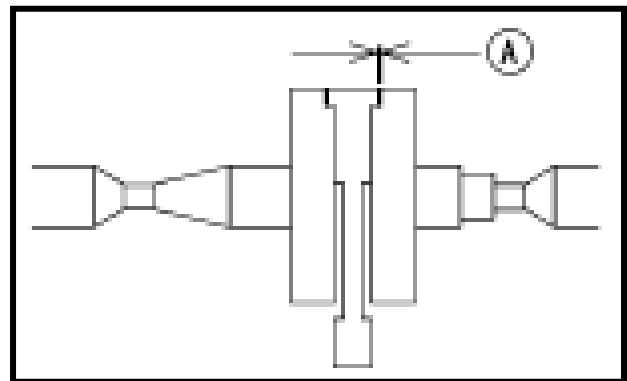

### Checking the run out :

- Place the crankshaft in a lathe or suitable support, place dial indicators as shown.
- Turn the crankshaft and record the readings. The maximum difference between the readings is the crankshaft run out.

#### **Run out:**

**Standard: 0.02 mm maximum**

**Tolerance limit: 0.08 mm**

If the run out exceeds the tolerance, replace the crankshaft or straighten it so that it meets the tolerance.

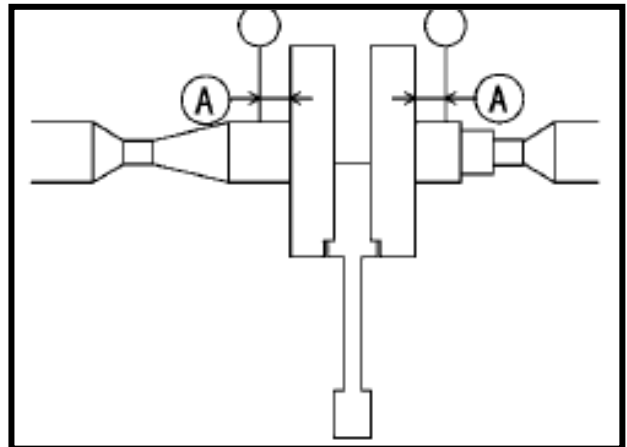

## Checking the center crankcases

- Inspect the general condition of the center crankcases for wear and cracks. Replace the center crankcase if necessary.
- Inspect the condition of all the bearings. Replace the bearings if necessary.
- Inspect the condition of the crankshaft bearings. Replace the crankshaft bearings if necessary.
- To remove the bearings, install tool number R464, heat the tool and the bearing.
- Remove the bearing.

*ATTENTION : The radial play in the roller bearings must be practically zero*





## Reassembling the central crankcase assembly

*ATTENTION : During the rebuild, replace all seals (paper, seal, o-ring...).*

- Install the crankshaft and counter balancer assembly in the left case, align the marks as shown.
- Install the transmission gear along with their corresponding shafts.

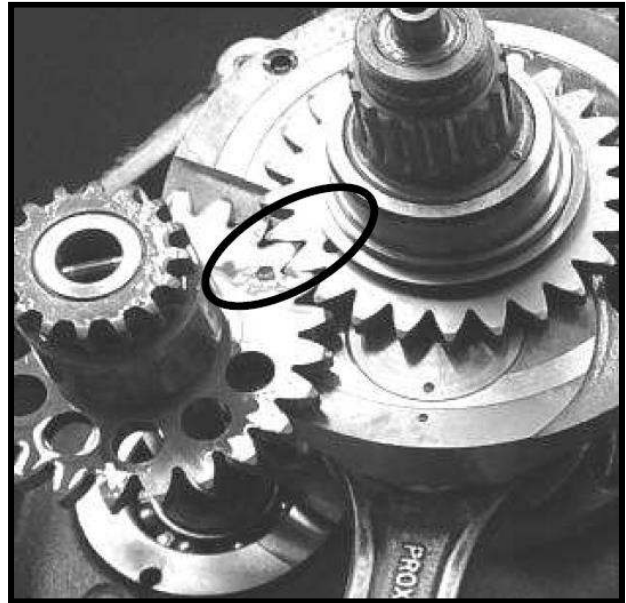

- Install a new roller on each shift fork.
  - Install the shift forks in the transmission in their respective grooves.
  - Install the gear selector drum.
  - Place the shift fork rollers in their respective grooves in the drum.
- Install the shift fork shafts

*ATTENTION : The center shift fork shaft is the smallest in diameter.*

*ATTENTION : Do not forget to lubricate all of the rotating and sliding parts.*

- Replace the two locating dowels in the case and install the washer on the transmission secondary shaft.

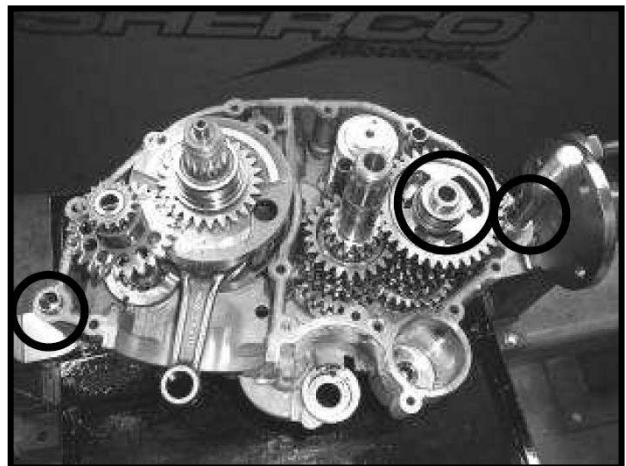

- On the right hand case make sure the breather jet is in place.
- Place the right case on the left case previously fabricated.
- Install the 13 screws that retain the two halves together.

**Torque the 13 center crankcase screws to: 10 Nm.**

- Install special tool number 2073 to keep the gear selector drum from rotating.
- Install the locating pin, the gear selector index wheel and the fixing screw.

**Torque the gear selector index wheel fixing screw to: 10 Nm.**

- Remove the special tool number 2073.
- Install the gear selector shaft.
- Install the oil pump shaft, the roll pin and the internal oil pump rotor.
- Install the oil pump cover and tighten the cover screws to the appropriate torque.

**Torque the oil pump cover screws to: 5 Nm.**

- Install the oil pump drive roll pin, the drive gear and the cir clip.
- Install the primary drive gear.
- On the transmission input shaft install the thrust washer, the needle bearings the clutch basket, the spacer washer, the clutch hub and the conical washer.
- Using an appropriate solvent clean the crankshaft threads and the input shaft threads.

- Install the fixing nuts on the crankshaft and the transmission input shaft.

- Apply the proper torque these fixing nuts.
- Install special tool number 1817 and torque the crankshaft fixing nut.

**Torque the crankshaft fixing nut to: 120 Nm.**

- With the special tool still installed, torque the transmission input fixing nut.

**Torque the transmission input fixing nut to: 80 Nm.**

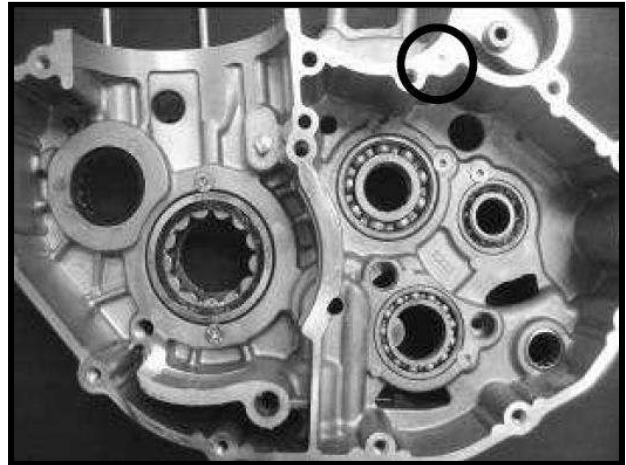

- Install the special tool that locks the engine at top dead center (ref 1819).
- Use tool 1817 to block the transmission and to tighten balancer nut.

**Torque of balancer nut 60 Nm + threadlocker.**

- Install the oil pump drive roll pin, the internal rotor and fixing nut to the cover.

**Torque of the oil pump cover : 5 Nm.**

- Heat the crankshaft spacer ring (ref 1732) to approximately 70 degrees and install it on the crankshaft.
- Replace the freewheel assembly and the starter drive gear train (see the paragraph on disassembling the left side).
- Reinstall the starter.
- Reinstall the motor top end (see the paragraph on the top end).
- Install the cam drive chain (see the paragraph on top end).
- Install the clutch (see the paragraph on disassembling the right side).
- Install the clutch cover.
- Install the spark plug.

**Torque the spark plug to: 15 Nm.**

*ATTENTION : Apply threadlocker to all of the internal engine threads except the five clutch pressure plate fixing screws.*

# TIGHTENING TORQUES

STANDARD TORQUE		THREADLOCKER
M5	6 Nm	
M6	10 Nm	
M8	24 Nm	
M10	40 Nm	
MOTOR TIGHTENING TORQUES		THREADLOCKER
Magnetic drain plug	15 Nm	
Drain plug with prefilter	15 Nm	
Oil filter cover	15 Nm	
Spark plug (with copper grease)	15 Nm	
Bolt for bleeding cooling system	6 Nm	
Ignition sensor screw	8 Nm	•
Bolt for draining cooling system	6 Nm	
Clutch slave cylinder screw	9 Nm	
Exhaust bolt	10Nm	
Cylinder head :		
1 <sup>st</sup> pass	30 Nm	
2 <sup>nd</sup> pass	45 Nm	
Hexagon nut M6	10 Nm	
Camshaft cap	10 Nm	
Chain tensioner screw (x2)	10 Nm	
Chain tensioner screw (x1)	10 Nm	
Timing control plug	8 Nm	
Chain guide screw	10 Nm	•
Clutch pression screw	10 Nm	
Water pump cover	11 Nm	
Rotor nut	80 Nm	•
Clutch nut	80 Nm	•
Oil breather wheel	8 Nm	
Ignition cover	10 Nm	
Crankcase screw	10 Nm	
Gear selector drum screw	10 Nm	
Oil pump cover	5 Nm	
Balancer nut	60 Nm	•

FRAME TIGHTENING TORQUES		THREADLOCKER
Rear wheel axle nut	100 Nm	
Aluminium sub frame bolts	24 Nm	•
Front wheel axle nut	40 Nm	
Front fork / axle boltes / axle M6	15 Nm	
Brake pad bolt	8 Nm	•
Botton plat fork bolts	WP 12 Nm Sachs 15 Nm	
Upper plat fork bolts	WP 17 Nm Sachs 17 Nm	
Motor screw	60 Nm	
Swing arm nut	100 Nm	
Cylinder head-frame screws	23 Nm	

# CLEAN INJECTOR BODY

---

## Material

- Minerva Net Carbu or carbu cleaner
- Allen keys of 2.5
- Screwdriver with 7mm dowel
- Wrench of 8



## Put down the injector body

- Remove the seat
- Remove the fuel tank
- Remove the injector body clamps
- Remove the throttle body cover
- Remove the throttle cable
- Remove the injector body



- Disconnect each connector
- Inspect



- Clean with carbu cleaner or universal product cleaner
- Blow



## Clean of injector body

- Clean the injector body with Net Carbu
- Make sure you clean perfectly the edge of the mixture throttle on each side by opening it completely
- Clean the injector Soufflez
- Blow



## Replace the injector body

- Put back all the parts together again, put some connector grease inside the electrical connectors (TPS plug, injector plug)  
**If you dismount the throttle body manifold, be careful with the sense of this part!**
- Set the throttle cable



- Disconnect the ECU connector. Inspect it
- Clean with carbu cleaner or universal product cleaner
- Blow



- Apply connector grease
- Connect to the ECU





## SYNERJECT INJECTION SYSTEM PRESENTATION

**1.1** Your Sherco 300 SEF-R (for 250 SEF-R, refer to the 2013 manual) is equipped with a Synerject injection system that is composed of a M3C computer, a Ø 42mm throttle body, a special ignition system and a special harness.

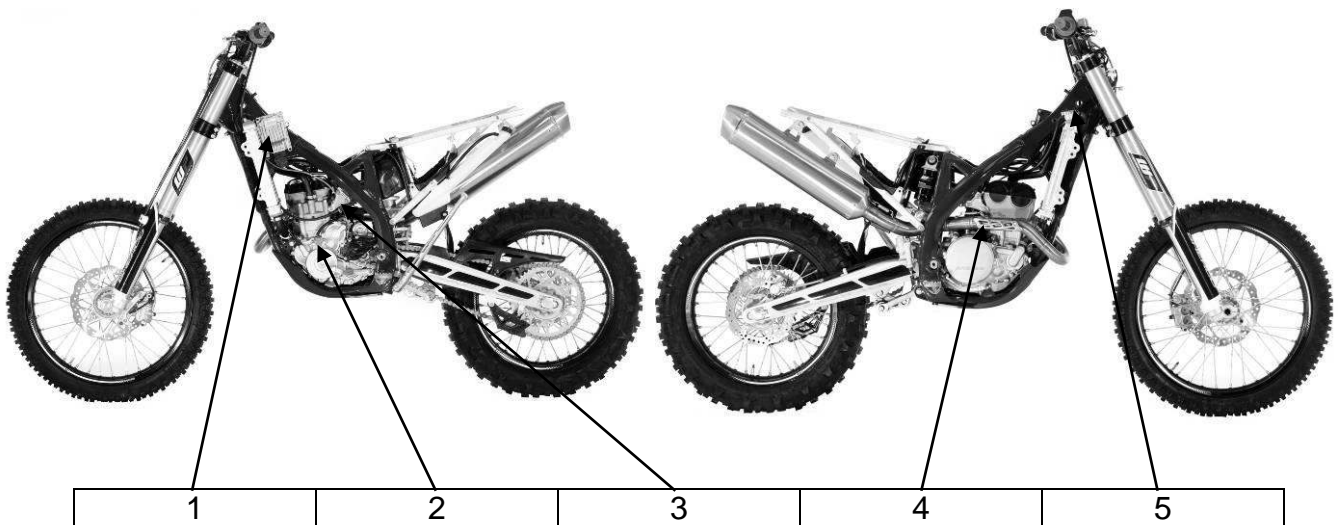

N°	DESIGNATION	LOCATION
1	Synerject M3C Computer	Left side of the frame
2	Engine speed sensor (pick-up)	Upper part of the ignition cover
3	Synerject injection unit Ø 42mm	
4	Water temperature sensor	The rear of the cylinder head
5	Diagnostic connector with double water protection (labeled ECU)	At the right front of the bike between the radiator and the frame

Photo 1 : Synerject M3C Computer

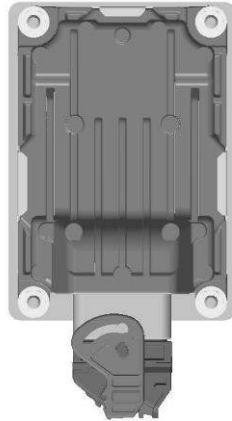
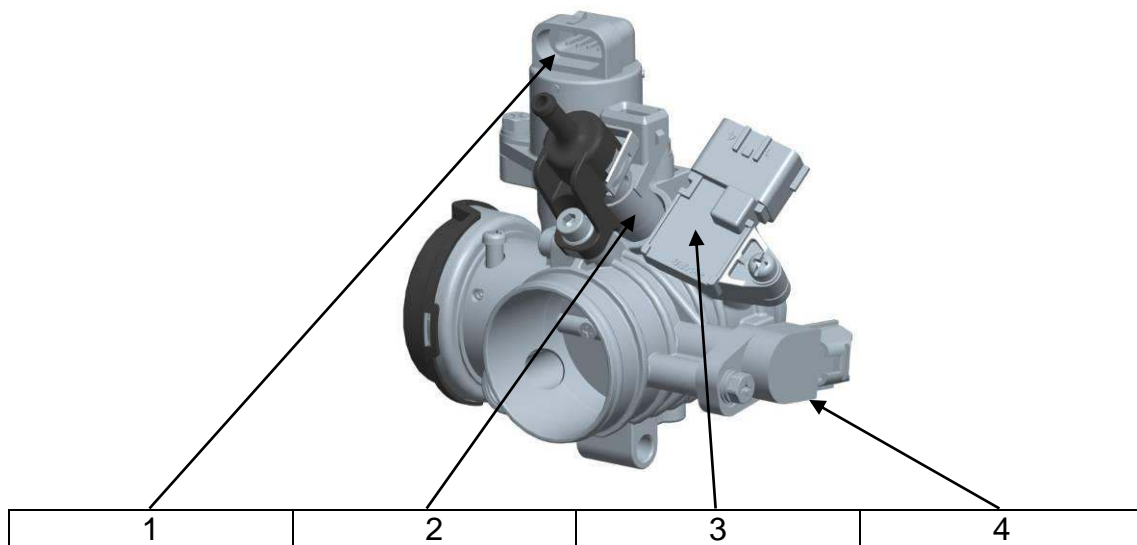

Photo 2 : Synerject injector body Ø42mm



N°	DESIGNATION
1	Stepper motor (Idle management and engine braking)
2	Injector
3	TMAP sensor (Air temperature/air pressure)
4	TPS: Butterfly position sensor

### 1.2- Description- Exxodiag diagnostic tool reference #4967

The diagnostic tool allows you to perform diagnostic operations, make updates to the injection mapping and to determine certain information (serial number of the motorcycle, number of hours of operation, etc.).

### 1.3- Diagnostic tool kit contents

The kit consists of a USB to MUX output cable, a MUX device, a MUX to motorcycle diagnostic connector cable, an installation CD and a user manual.

## 1.4- Installation of the diagnostic tool

*In case of problem during the installation, please contact EXXOTEST at +33 (0)4 50 02 34 34 or by mail to [courrier@exxotest.com](mailto:courrier@exxotest.com).*

### A- Installing the software and drivers :

- Open the installation CD on your computer

- Run « Sherco\_Setup »

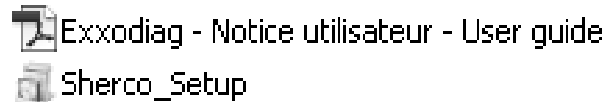

- Select the desired language



- Click « Next »

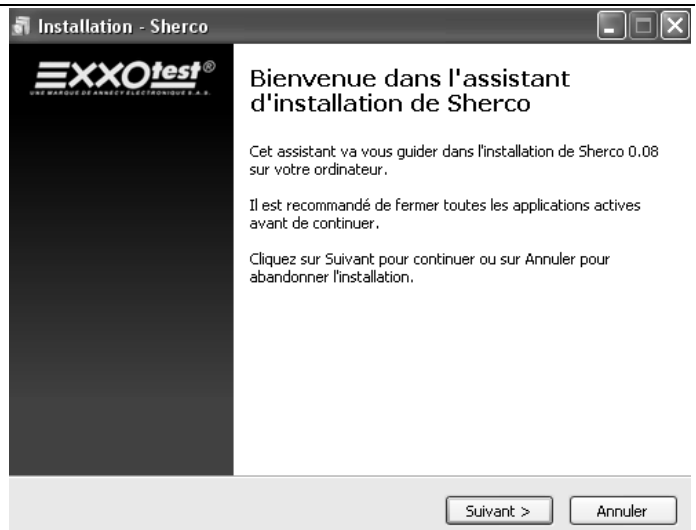

- Select the folder where you want the software to be installed

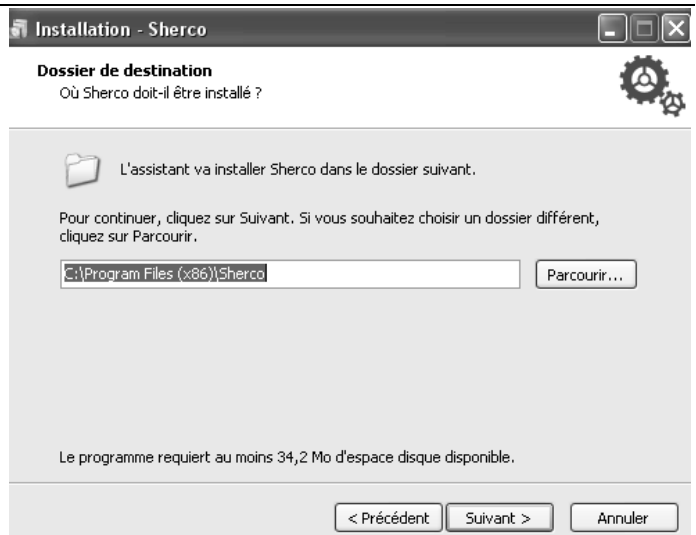

- Click « Next »



- Click « Install »

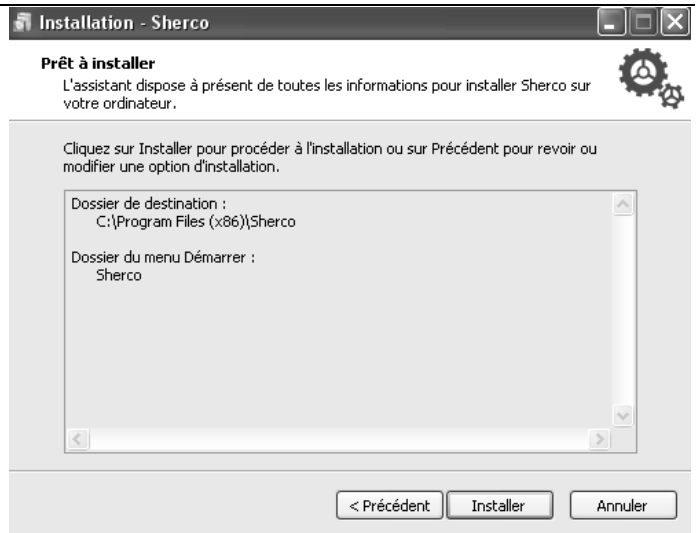

- Installation is in progress

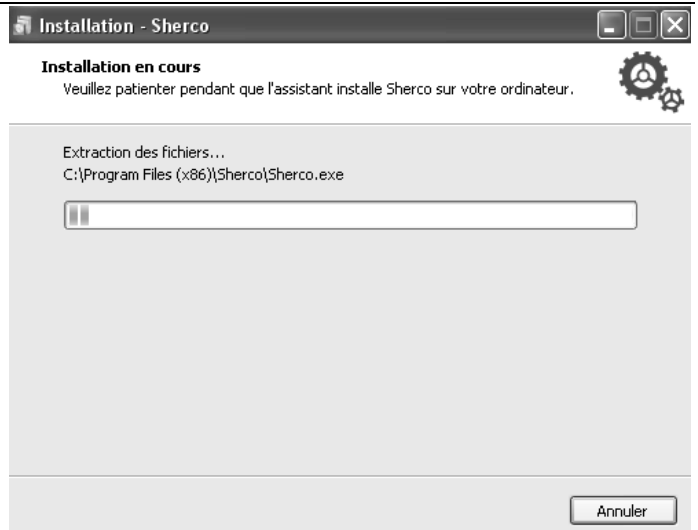

- Select « Start installing drivers » and « Finish »



- The following window opens. Read the terms of the licence agreement. Select « I accept the terms of the license agreement » and « Install ».



- Installation in progress

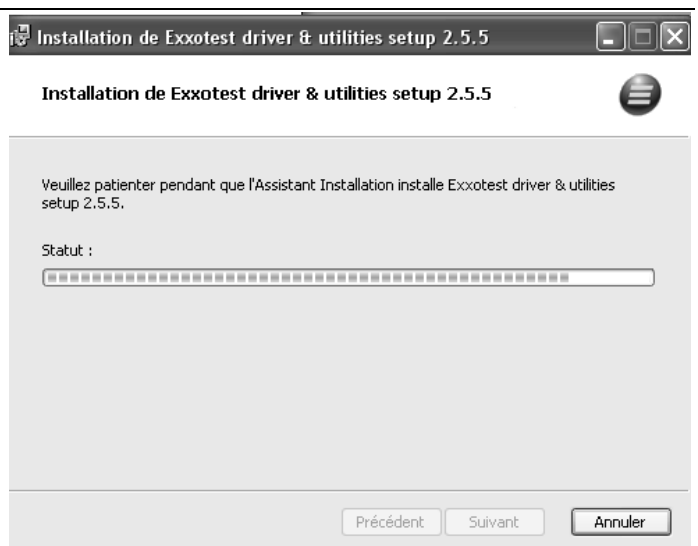

- The following window opens. Click « Finish »

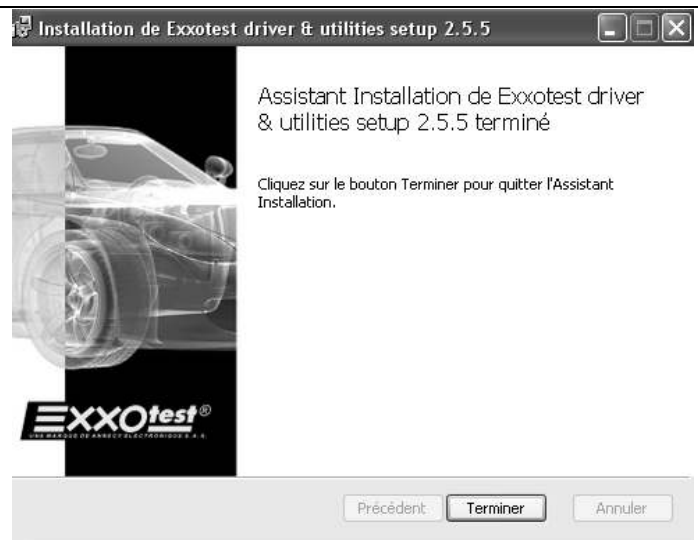

The installation is complete.

B- Connect one end of the "MUXDIAG II" interface cable to a USB port on your computer.  
Connect the other end to the diagnostic connector on the motorcycle.

Check to make sure that the "MUXDIAG II" is receiving power. The LED lights should be lit:

- Solid blue: The PC connection has been successfully established
- Flashing blue: Connected to current PC
- Blue LED off: The PC is off or in standby mode or there is a problem with the USB connection
- Steady green: There is a problem with the software
- Flashing green (slow): The software is functioning correctly
- Flashing green (fast): Connected to current PC
- Green off: The firmware is not present
- Solid red: The card is receiving power

All LED's off : The unit is not plugged in, it is in standby mode or there is a USB problem

# SOFTWARE PRESENTATION

---

## 2.1- Connection with Keyless system

Sherco had a Keyless system on its motorcycles which allows the bike to switch on without any key and switch off automatically after 30seconds of non-use.

This last point blocks the diagnostic, this is why it is necessary to follow the steps down below before doing it.

1. Remove the plug (1) from the connector (2) (located on the rear sub frame – on the right part of the bike).

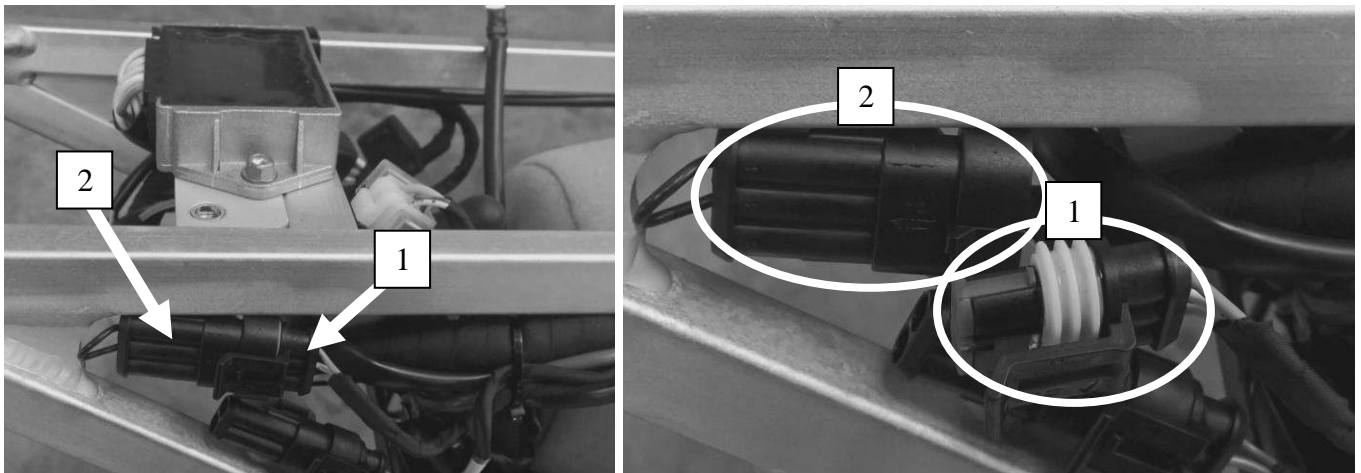

2. Take the shunt (3) (reference 6267) and connect the plug (1) into it.

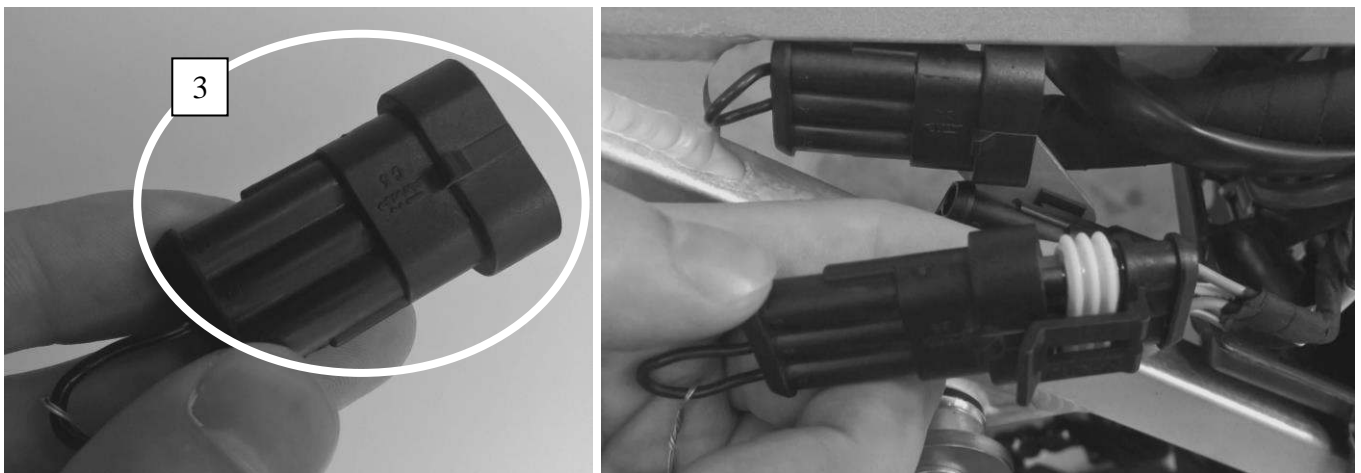

3. You can now do the diagnostic by following the next explanations.

Note: In order to establish connection with the bike it must be turned on (ON).

To navigate through the various menus only the USB cable with the "MUXDIAG II" box must be connected to the computer.



Start the software by using this icon.

Go to the following menu:



Diagnostic Menu (diagnosis, updates mapping, etc)	Setup Menu (language selection, units, etc)	Update and sync Menu (software update, proxy settings)	Help
---	---	---	------



## 2.2- Software setup : configuration menu



Configuration

	Périphérique de communication	USB MUX DIAG V2 n°5438	
	Langue	Français	
	Niveau d'autorisation	Après-vente	
	Type d'unité	<input checked="" type="radio"/> Unité par défaut <input type="radio"/> Unité équivalente	

?

Sherco v0.08

### Configuration

	Communication peripheral	USB MUX DIAG V2 n°5438	
	Language	English	
	Authorization level	After sales	
	Type of unit	<input checked="" type="radio"/> "Default" unit <input type="radio"/> Equivalent unit	

In this menu you can change the following:

- Taking a diagnostic reading. You can refresh the list by clicking on this button. .  
Le n° doit correspondre au n° du boîtier "MUXDIAG II".
- The languages included on the software include: French, English, Spanish, Portuguese, German and Italian (If the CD that you have does not include these languages. Perform a software update, -> page 49).
- Choose the desired units.
- Click on to return to the home screen
- Click on to validate your changes

## 2.3- Menu update and synchronization



### A- With this menu you can update the diagnostic software tool :

- To determine if a software update is available, make sure that you have an internet connection and then click this icon.



- If an update is available, the following window will appear :

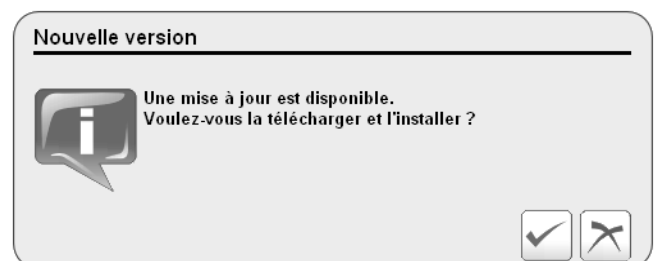

- If no update is available, the following message appears :



- 
- Click on  in order to start the download of the update.

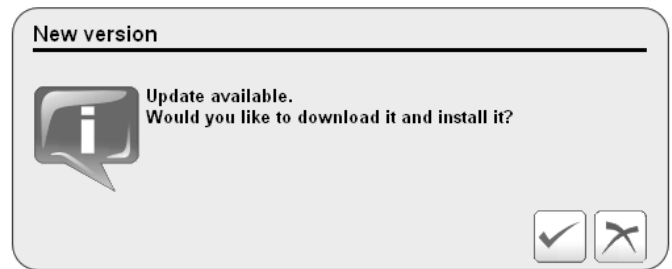

- 
- The following message will appear:
  - Click on  to start the installation.



- Repeat the setup steps -> page 42. It is not necessary to reinstall the drivers.

## B-Configure the internet access settings

You may need to set up a Proxy server in order to access the internet.



- Click on this icon

---

- Complete the following settings if necessary

### Configuration of proxy settings

- None
- Use the following settings

#### Customized settings

Address / Port	<input type="text"/>	<input type="text"/>
User	<input type="text"/>	
Password	<input type="text"/>	



- Click on  in order to save your changes

## USING THE SOFTWARE



Diagnostic menu and updating the injection mapping

### General :

Click on « Sherco »

Choose vehicle

 After sales	<input type="text" value="Sherco"/>
 USB MUX DIAG V2 N°5438	

Click on « M3C »

Choose ECU

 After sales	<input type="text" value="M3C"/>
 USB MUX DIAG V2 N°5438	
 Sherco	

You get the following menu :

**Choose vehicle**

After sales	Identification
USB MUX DIAG V2 N°5438	Parameter reading
Sherco	Trouble codes reading
M3C	Trouble codes clearing
	ECU updating
	Actuator tests

**A-Identification** : You can check the identification of the following (serial number, hours of operation, calibration number)

**Reading of current setting...**

Factory	VIN code	VNBS430E32B001821
USB MUX DIAG V2 N°5438	Overall engine operating hour counter	0.0 h
Sherco	ECU Board Serial Number	2011929783
M3C	Software Version	QR010010
	Hardware Version	S18003704029
	Calibration	25EUS01.

**B-Parameter measurements** : general parameters (speed, pressure, stepper, etc)

**Choose category...**

After sales	Engine information
USB MUX DIAG V2 N°5438	Throttle Position
Sherco	Misc
M3C	

## 1-Engine information :

Displayed below are the main system values :

Reading of current setting...

 After sales	RPM	0 tr/mn
 USB MUX DIAG V2 N°5453	Engine Temperature	31 °C
 Sherco	Battery Voltage	11.9 V
 M3C	Air temperature	28 °C
	Ambient pressure	1012 mb
	Stepper position	0
	Throttle position	0 %

### Details :

- Stepper Position: The air valve (stepper) opening value ->  $35 < \mathbf{50} < 75$   
If the value is too low: there could be an air leak at the engine air intake  
If the value is too high: there could be dirt in the injector butterfly area

Note : The correct air valve motor value should be 15mm and 2mm with the motor idling and at 80°C.

-Butterfly position: With the engine stopped it should be 0%: the maximum opening value should be 100%. If the value is not 0% with the engine stopped it means that it needs to be adjusted. Perform a system reset several times (Switch the ignition off. Wait until the ECU relay shuts. Put it on the bike). The pitch should be 0.5%.

-Emergency stop button: the status of the emergency stop button. 0: off, 1: on.

-Engine status: ES (engine ready to start), ST (engine running), IS (engine is at idle), PL (acceleration), PU (deceleration), PUC (injection cutoff deceleration)

2-Other less frequently used values appear in the windows :

Throttle position :

- The adjustment value for the minimum throttle butterfly opening should be (in V): 0.4<**0.5V**<0.6

Miscellaneous :

- Manifold Pressure (mb): pressure at the injector nozzle body measured by the TMAP sensor

-Engine synchronization status: engine cycle recognition.

0: engine not in phase.

1: engine running in phase.

-The full engine idling adaptation (%): not activated function

---

**C-Reading the default codes :**

When you click on "read default codes" the system starts checking.

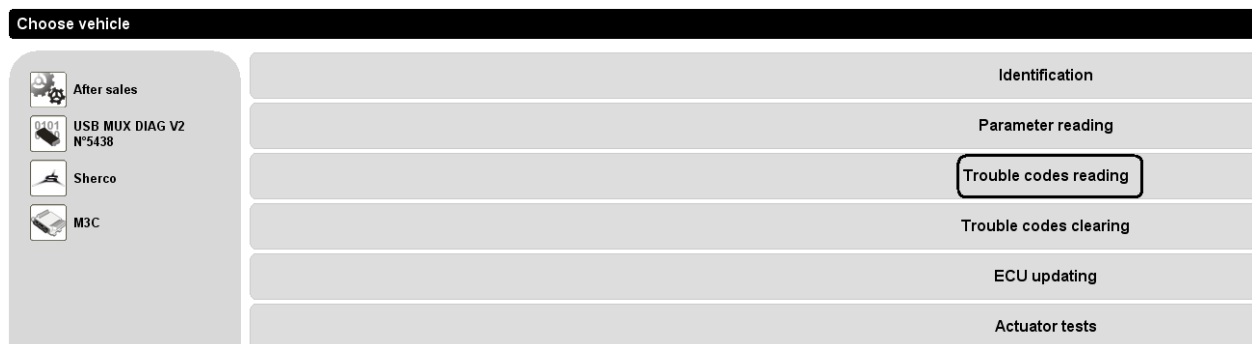

If no default appears exit the menu by clicking on this icon



If a default appears :

**Breakdown list...**

After sales  
USB MUX DIAG V2  
N°5438  
Sherco  
M3C

Fugitive failure Permanent failure

Throttle Position Sensor (P0122)  
Electric fuel pump (P0231)  
Air pressure sensor (P0107)  
Intake air temperature sensor (P0113)  
Stepper motor (P1508)  
Cooling fan (P0485)

You can get the details of the default by clicking on the default display :

**Details of breakdown code...**

After sales  
USB MUX DIAG V2  
N°5438  
Sherco  
M3C

Throttle Position Sensor (P0122)  
Short circuit to ground or overload

- Number of occurrence of present failure = 59
- RPM = 0 tr/min
- Engine Temperature = -40 °C
- Battery voltage = 4,0 V
- Air Temperature = 29 °C
- Ambient pressure = 64 mb
- Applied Ignition angle = -29 °CRK
- Injection Time = 35 ms
- Engine state = ES
- Overall engine operating counter = 0 h
- Engine operating minute counter since last engine start = 237 min
- Throttle Position in degrees = 0 °TPS
- Intake manifold air pressure = 1360 mb
- Mass air flow = 40 mg/tdc
- Adaptive value of integral term of the idle speed controller = -50.00 %

-Record the defaults and exit the menu by clicking on this icon





Note :

1- Transient default/permanent default : a transient default becomes permanent after a certain number of engine cycles of the following components (injector, fuel pump, etc). For a permanent default to disappear it takes 40 cycles without the engine default reappearing.

2- Fan Default : If there is no fan installed on the bike, there will always be a rise in the fan default code (P0485)

---

## D-Erasing default codes

1-If a default appears : go to the menu « Erasing default codes »

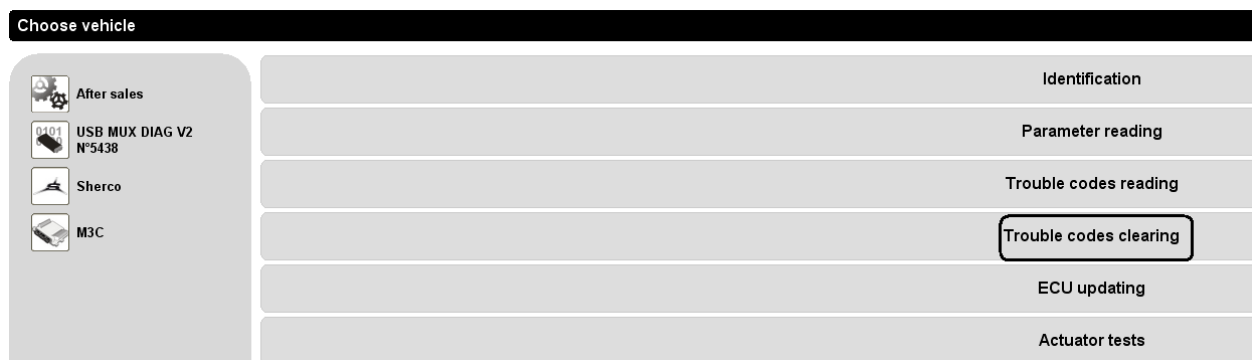



Effacer tous les codes défauts ?

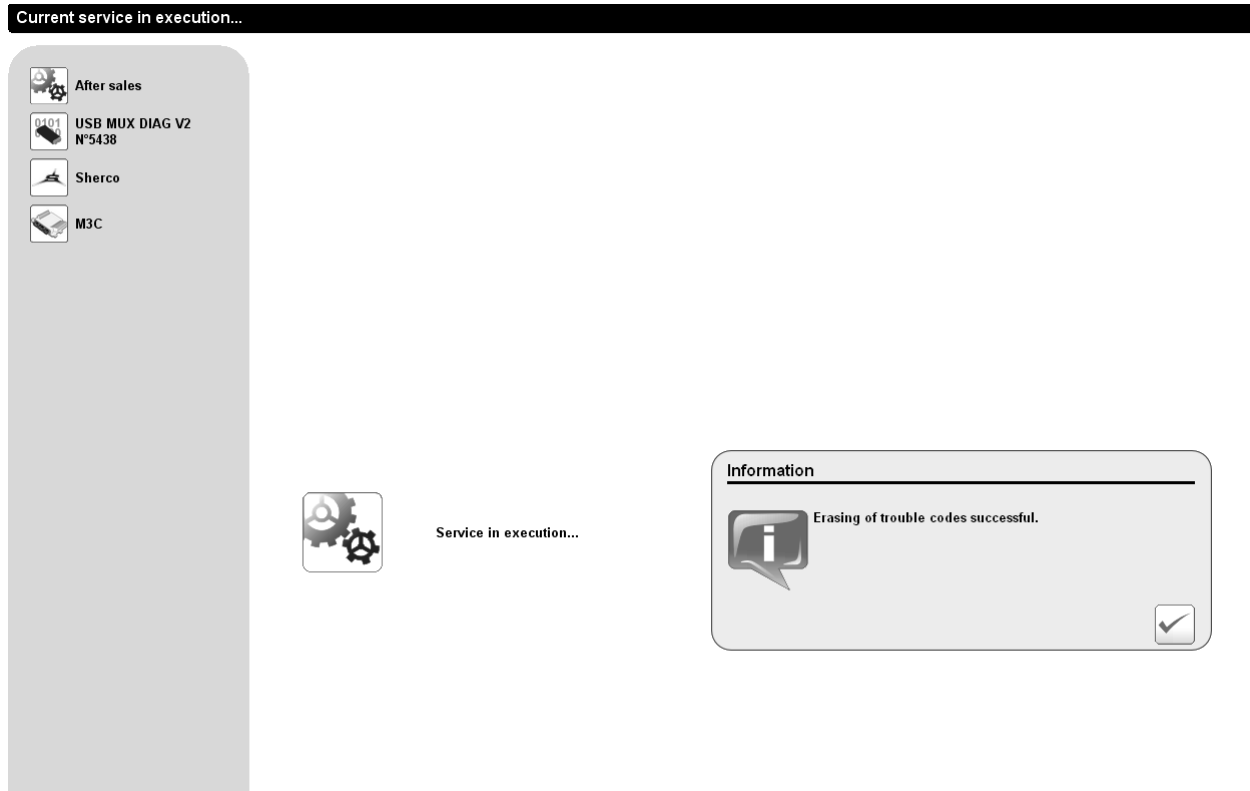

Click this icon  in order to erase all of the default codes

The following screen will appear :



Confirm by clicking on this icon 

2-Return to the menu « reading default codes » :

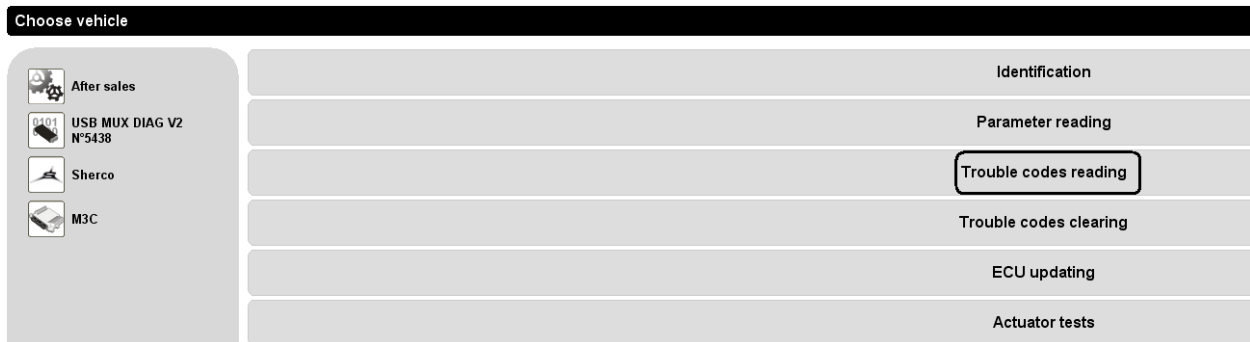

Check and make sure that the defaults are the same as before. Check/replace the defective parts. Check all of the connections.

## E-Test the actuators

In addition to reading default codes you can also check some of the system components :

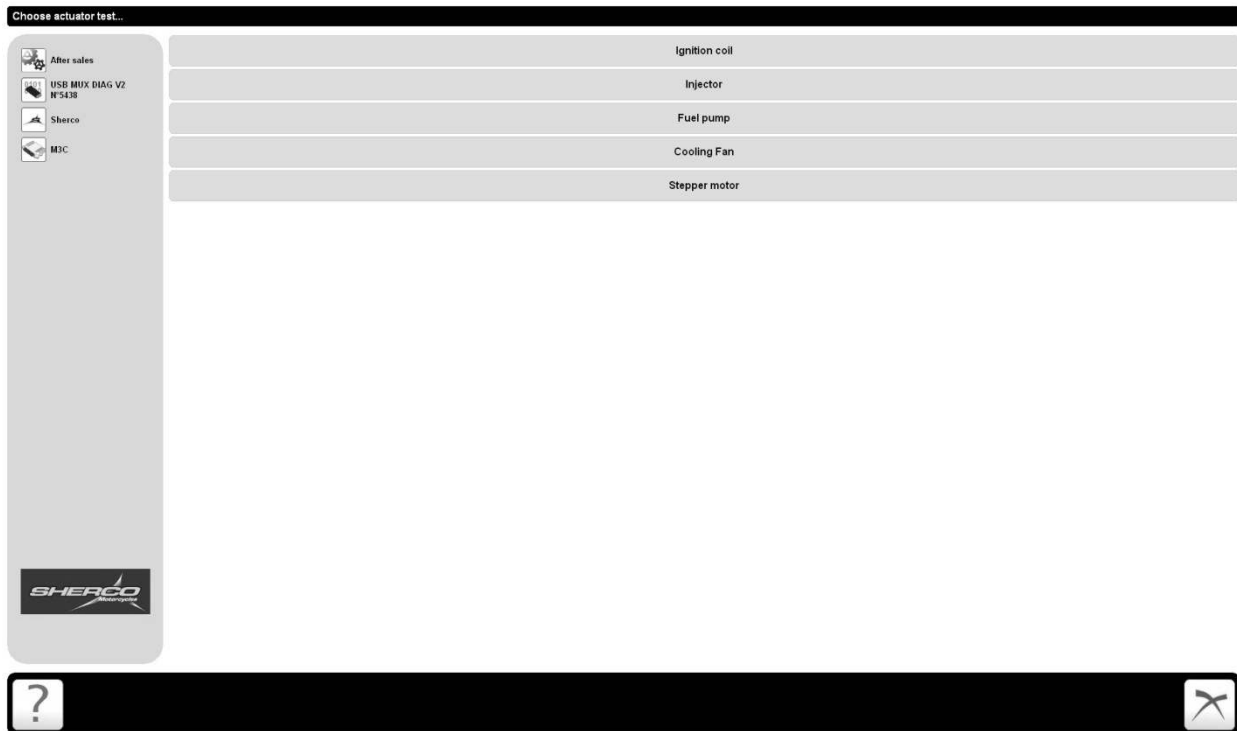

### 1-Ignition coil

When you launch the ignition coil test, the following message will appear :



The system is not able to detect an ignition coil failure with the engine stopped. The test results will be the same if the coil is faulty or not. Therefore, when testing the ignition coil make sure that the engine makes the correct sound for a properly functioning ignition coil.

---



---

## 2-Injector

This is the same type of test as with ignition coil. Make sure that the injector issues a snap when activated.

---

## 3-Fuel pump/fan/stepper

For the fuel pump, the fan and the stepper (air valve) perform a standard test. If there is a default it will appear as a classic default.

Example of a functioning stepper :

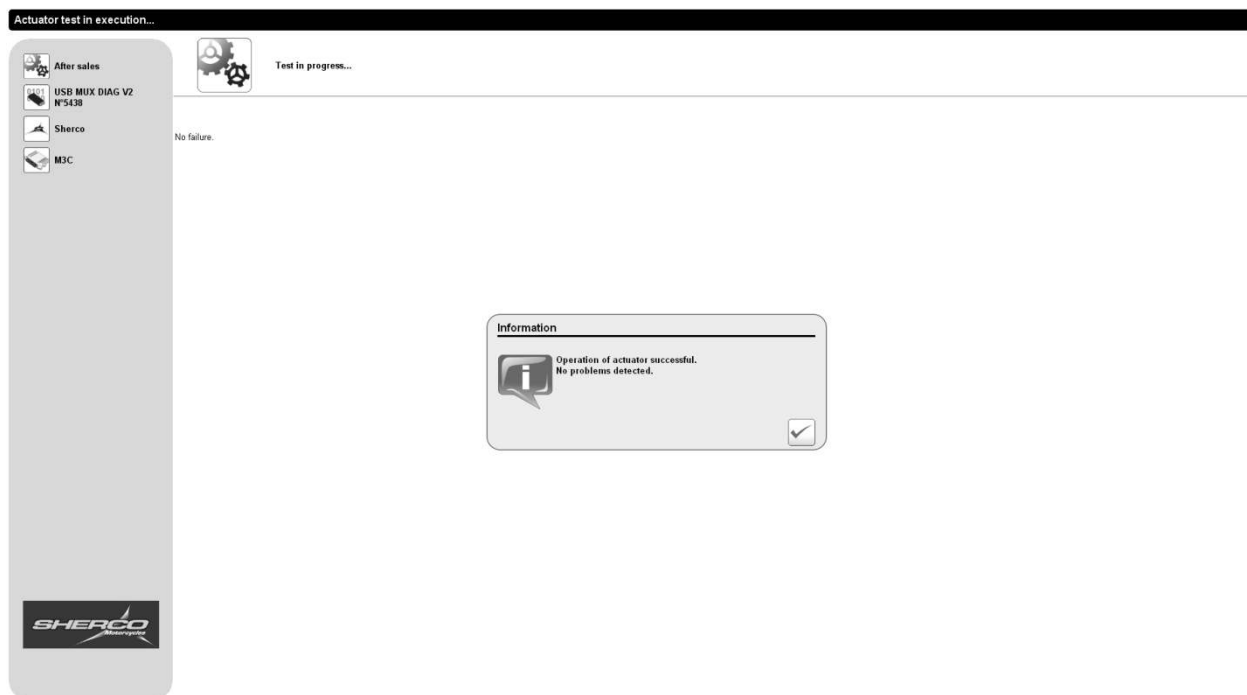

Stepper default :

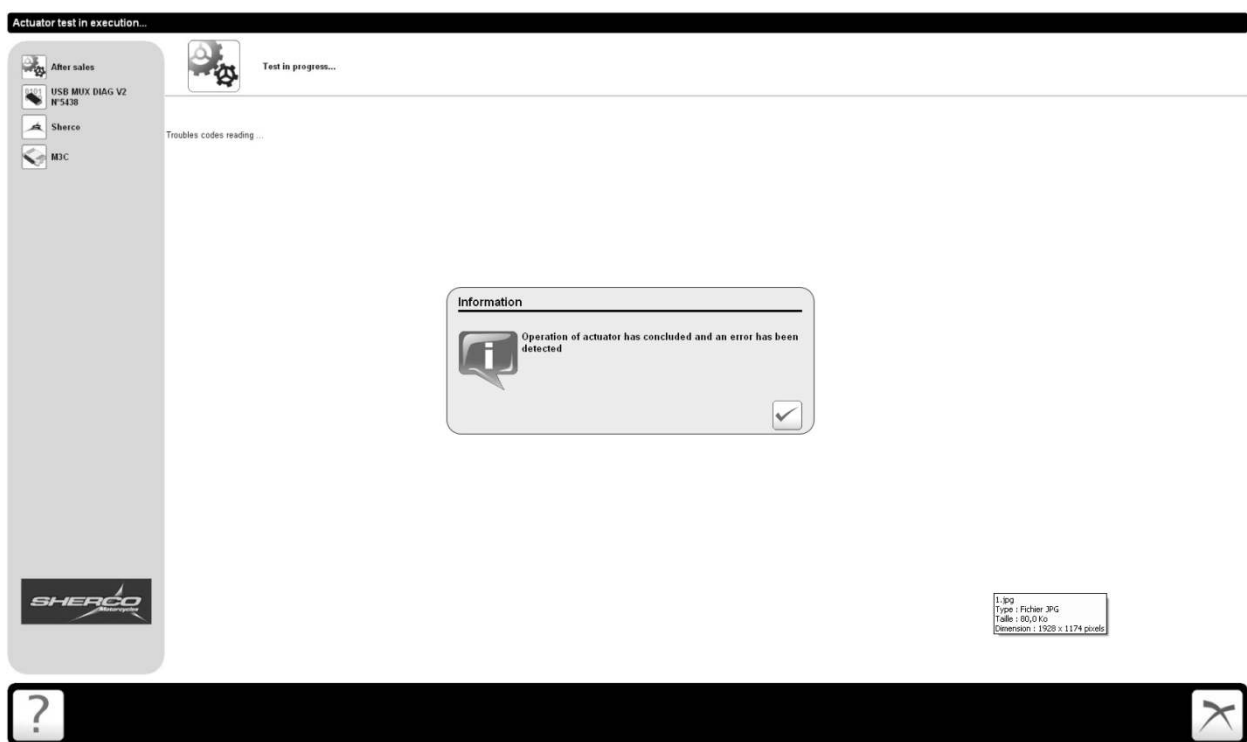

In the event of a reoccurring default, check/change the defective parts.

Note : The fan test is meaningless if the bike is not equipped with a fan.

## F- Updating the computer :

By using the diagnostic tool it is possible to make updates to the injection mapping (calibration). An example would be the fitting of a racing silencer or there is an update from the factory. These files will be freely available on sherconetwork (end 2013):

**You must pay attention to the model, the displacement, the type of silencer, etc.**

In case of doubt, contact technical support.

1-Download the desired update (file.mot)

2- Power up the motorcycle

3-Click on the computer update

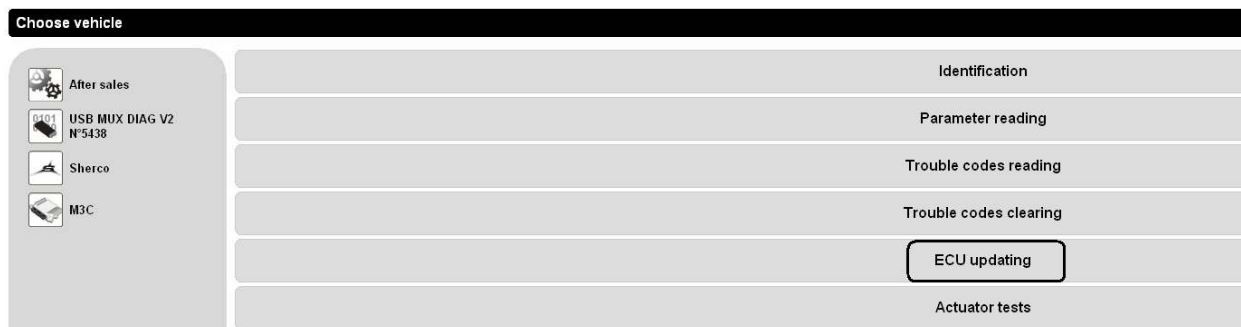

**Update ECU now ?**

Confirm by clicking on this icon



Select the calibration file (.mot) that was previously downloaded and click open.

4- The file is being downloaded



Downloading ... (14.2%)

**ATTENTION !**  
**DO NOT TURN OFF THE MOTORCYCLE DURING THE DOWNLOAD OPERATION**  
**(FLASH)**  
**DO NOT ABRUPTLY STOP THE FLASH DOWNLOAD PROCESS**  
**THERE IS A RISK OF IRREPAIRABLE DAMAGE TO THE COMPUTER**

5- At the end of the download the fuel pump will start and the following message will appear :

INFORMATION : Download was successful

Confirm by clicking on this icon 

6-Check to make sure that the correct calibration file was allocated by clicking on « Identification »

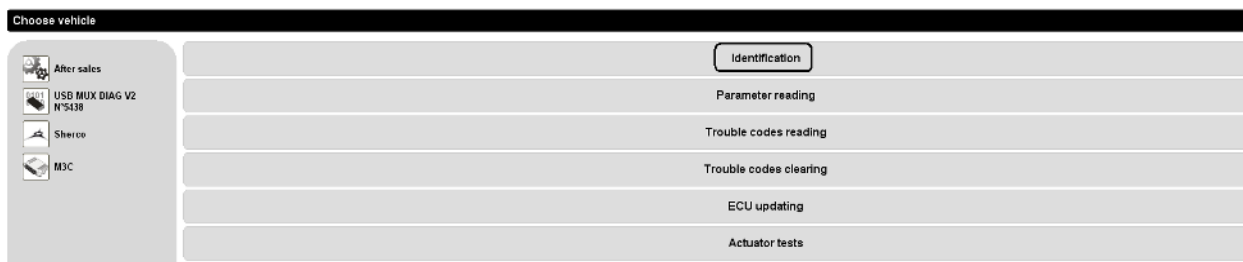

Check to make sure that the file name matches the file that was downloaded

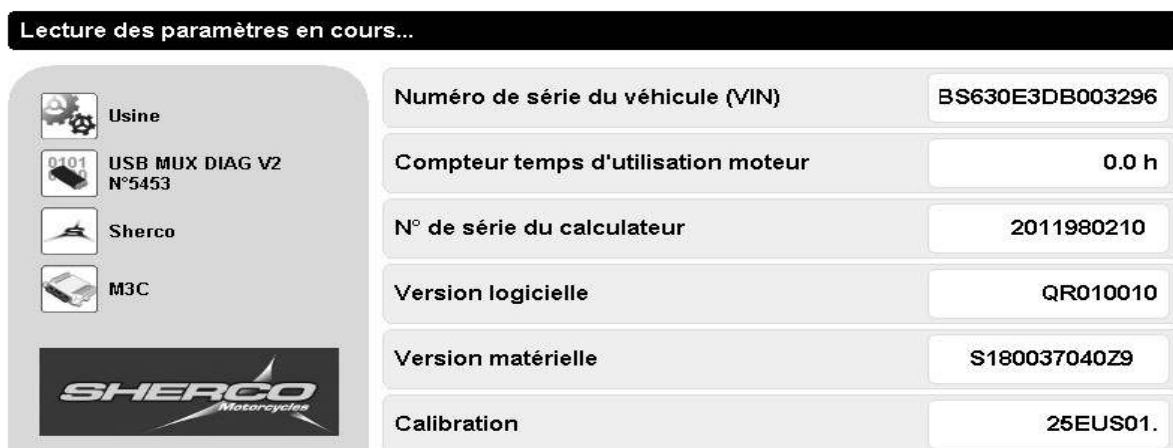

Note: Serial number information and operating hours are not reset during a calibration update.

7- Start the motorcycle and make sure that the engine parameters are normal (idle, stepper opening, etc).

## G- Screen printing function



If you are communicating with technical support and need help identifying potential problems you can perform a screen print operation by pressing F10 on your keyboard. This will allow you to attach these files to your inquiry.

The "identification" screen contains all of the important information about the motorcycle (serial number of the bike, number of hours of operation, calibration, etc).

Reading of current setting...

Factory	VIN code	VNBS430E32B001821
USB MUX DIAG V2 N°5438	Overall engine operating hour counter	0.0 h
Sherco	ECU Board Serial Number	2011929783
M3C	Software Version	QR010010
	Hardware Version	S180037040Z9
	Calibration	25EUS01.





# ELECTRICAL INSTALLATION CHECKING

## 1- Static values (engine off)

Tension battery > 12.5V

Stator resistance :

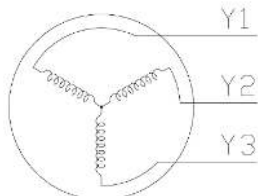

Y1-Y2	0.44Ω±15%
Y2-Y3	
Y1-Y3	

Pick up sensor : 120 Ω±10%

Check there is no continuity between stator and the ground of the motorcycle

## 2- Dynamic values :

Pick up sensor :

1.7V MIN/300 tr/min

120V MAX/10000 tr/min

Regulator :

Alternatif (calibre 200V alternatif)

Idle speed 22V ±2V

A 6000 tr/min : 77V±3V

Continue

Regulator pins out (Caliber 20V continue)

A 4000 tr/min : 14.6V + Red/White, - Green

Generator :

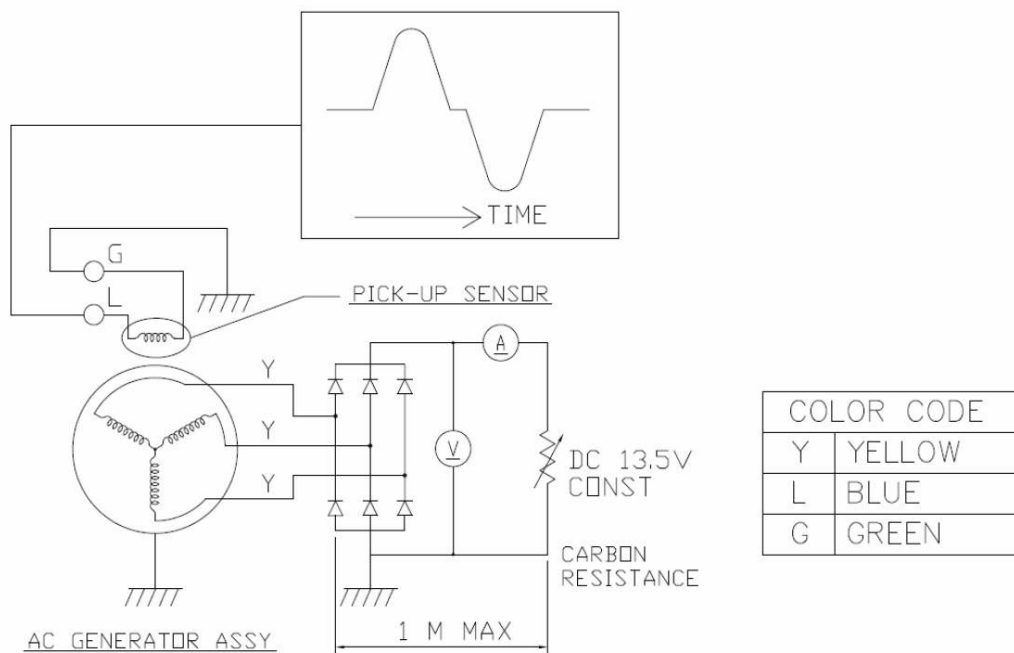

Tolerance on typical values= -5% /+10%

RPM	VOLTAGE (AC)	CURRENT (IB) (DC)	VB
2000	25.0V	14A	DC 13,5V
2500	31V	15,0	
3000	38V	15,6	
4000	51V	16,2	
5000	63V	16,4	
6000	76V	16,8A	
7000	92V	16,6A	
8000	101V	16,7A	
9000	114V	16,8A	
10000	125V	17A	

# CONTROLS OF THE SENSORS

## CONTROL TPS SENSOR

1. Remove the injector body from the bike.

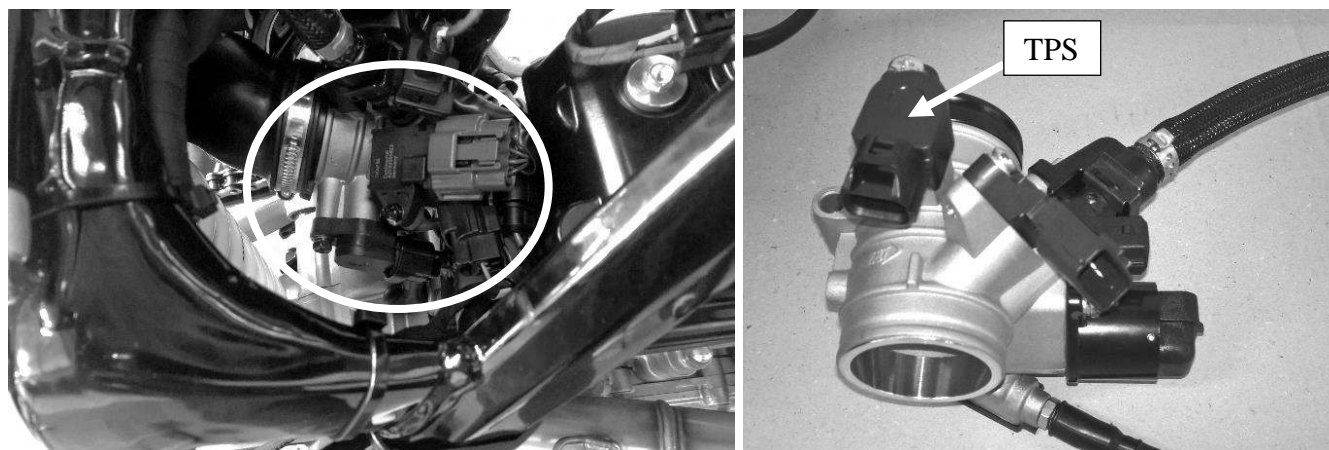

2. Control the resistance of the TPS as done below.



3. Values (in k $\Omega$ ).

### Butterfly closed :

- Between + (red) and – (black) : 5 +/- 0.5
- Between signal (blue) and – (black) : 1.25 à 1.55
- Between signal (blue) and + (red) : 5.3 +/- 0.5

### Butterfly fully open :

- Between + (red) et – (black) : 5 +/- 0.5
- Between signal (blue) et – (black) : 4.6 +/- 0.4
- Between signal (blue) et + (red) : 2.05 +/- 0.3

## VALUES OF TEMPERATURE SENSOR

---

TEMP (°C)	RESIST (K Ω)
-40	100.950
-30	53.100
-20	29.121
-10	16.599
0	9.750
+10	5.970
+20	3.747
+25	3.000
+30	2.547
+40	1.598
+50	1.150
+60	0.746
+70	0.565
+80	0.377
+90	0.275
+100	0.204
+110	0.153
+125	0.102

## CABLE DIAGRAM

### Injection beam

REF	FONCTION
002	Light harness connector
1010	Electrical starter
1020A	Pick up sensor
1020B	Generator
1020C	Regulator
1042	General Relay
1135	Bobine HT
1211A	Fuel pump
1211B	Dashboard
1225	Stepper motor
1290	TPS sensor
1303	ECU relay
1310	TMAP sensor
1320	ECU
1330	Injector
1510	Fan harness connector
4020	TCO sensor
8235A	Electrical starter relay (relay)
8235B	Electrical starter relay (battery)
8235C	Electrical starter relay (motor)
8235D	Electrical starter relay motor
9901	Double mapping
9902	Emergency stop
C001A	Diagnostic connector
C001B	Diagnostic connector
C001C	Diagnostic connector plug
Fusible	Fuse 15A
MM01	Engine ground
BB00A	+ Battery
BB00B	- Battery

### Diagram :

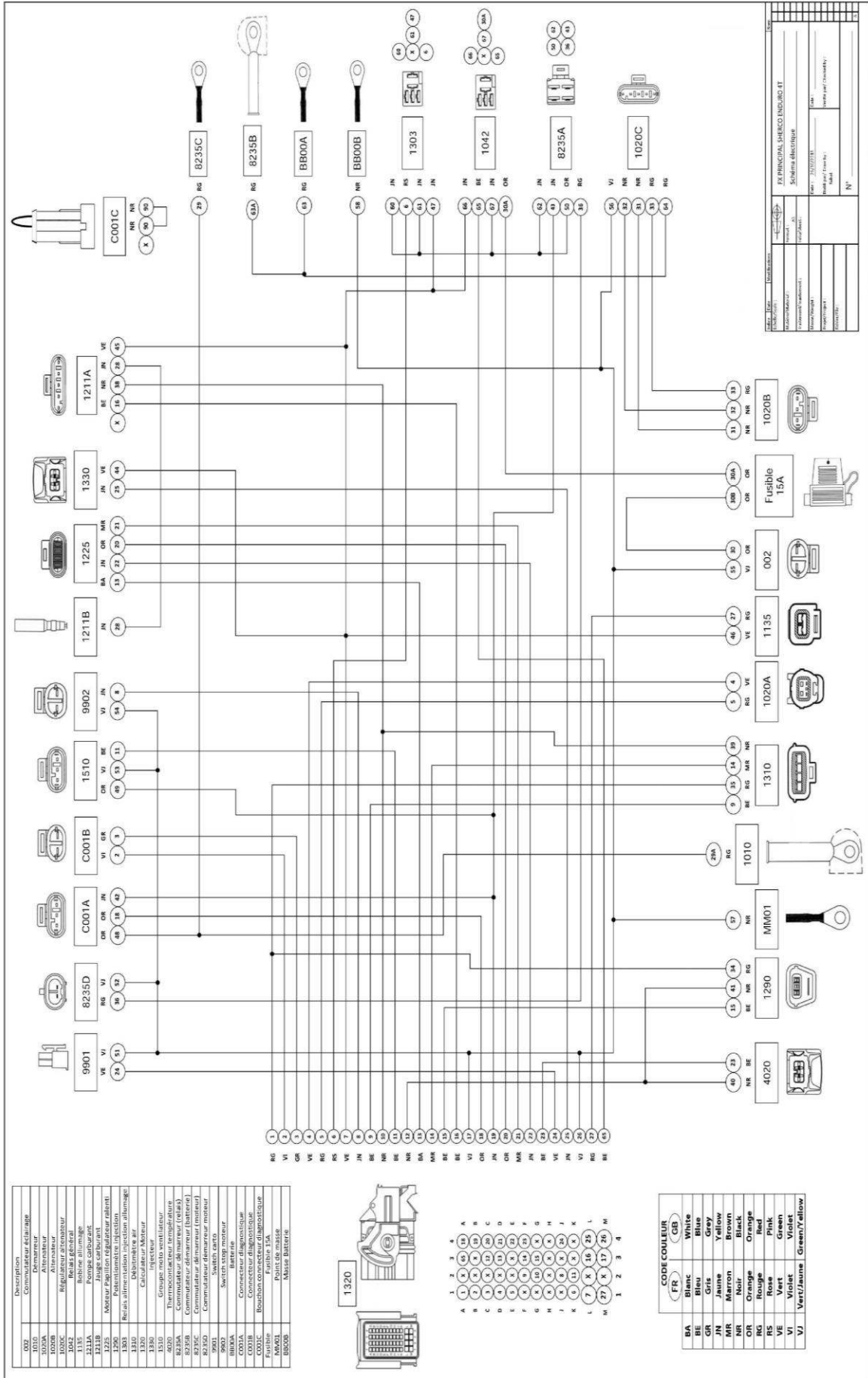

# Geometry :

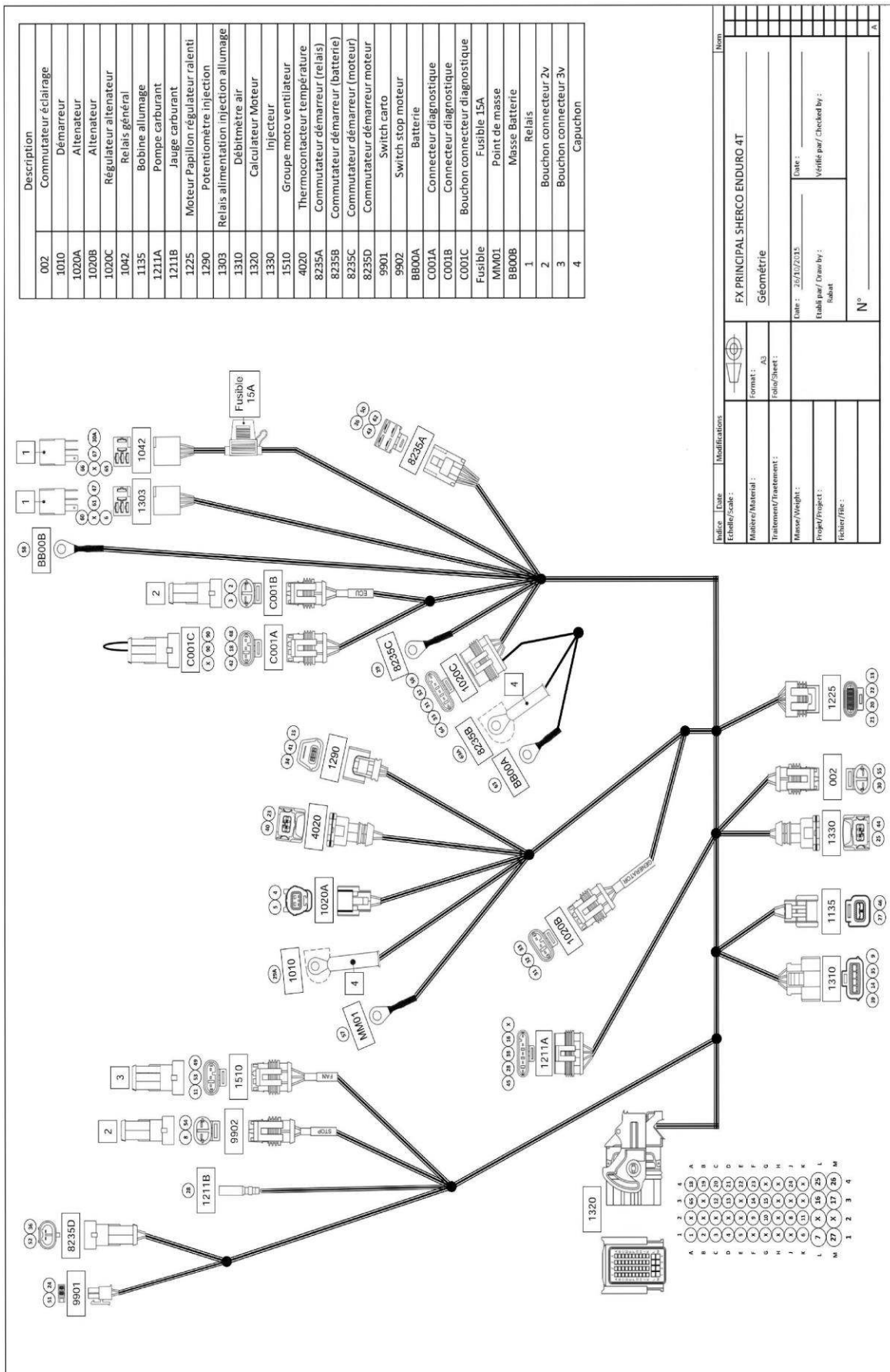

Description	
Commutateur éclairage	002
Démarrateur	1010
Alternateur	1020A
Alternateur	1020B
Régulateur alternateur	1020C
Relais général	1042
Bobine allumage	1135
Pompe carburant	1211A
Jauge carburant	1211B
Moteur Papillon régulateur ralenti	1225
Potentiomètre injection	1290
Relais alimentation injection allumage	1303
Débitmètre air	1310
Calculateur Moteur	1320
Injecteur	1330
Groupe moto ventilateur	1510
Thermocontacteur température	4020
Commutateur démarreur (relais)	8235A
Commutateur démarreur (batterie)	8235B
Commutateur démarreur (moteur)	8235C
Commutateur démarreur moteur	8235D
Switch carto	9901
Switch stop moteur	9902
Batterie	BB00A
Connecteur diagnostique	C001A
Connecteur diagnostique	C001B
Bouchon connecteur diagnostique	C001C
Fusible 15A	Fusible 15A
Point de masse	M/M01
Masse Batterie	BB00B
Relais	1
Bouchon connecteur 2v	2
Bouchon connecteur 3v	3
Capuchon	4

Indice : \_\_\_\_\_ Date : \_\_\_\_\_ Modifications : \_\_\_\_\_  
 Echelle/Scale : \_\_\_\_\_  
 Matière/Material : \_\_\_\_\_  
 Traitement/Traitement : \_\_\_\_\_  
 Masse/Weight : \_\_\_\_\_  
 Profil/Project : \_\_\_\_\_  
 Fiche/Fiche : \_\_\_\_\_

Form : A3  
 Folio/Sheet : \_\_\_\_\_

Date : 29/10/2015  
 Établi par / Draw by :   
 Vérifié par / Checked by :   
 N° \_\_\_\_\_

FX PRINCIPAL SHERCO ENDURO 4T  
 Géométrie

# 250 SEF light system cable diagram

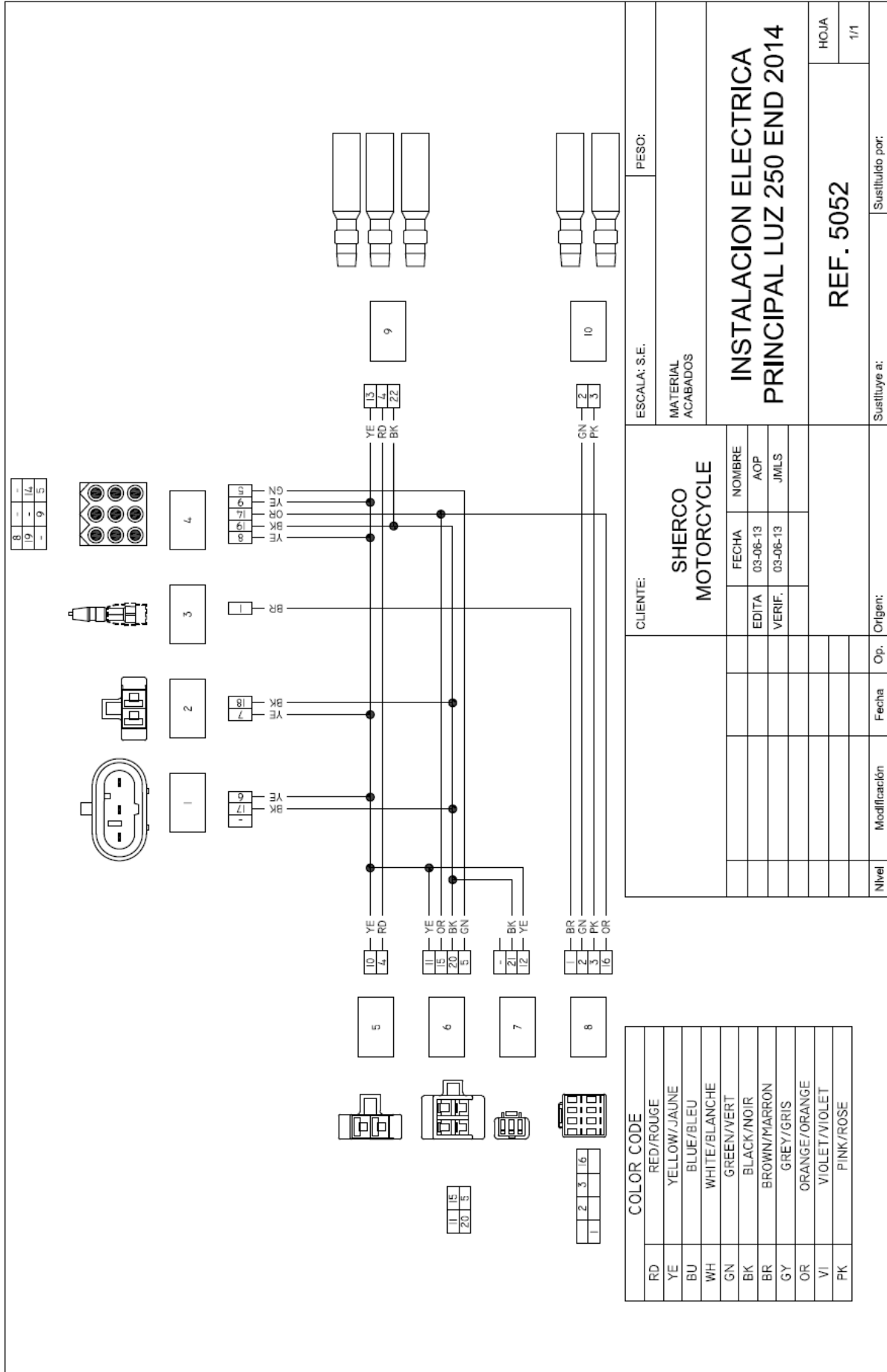



# 300 SEF light system cable diagram

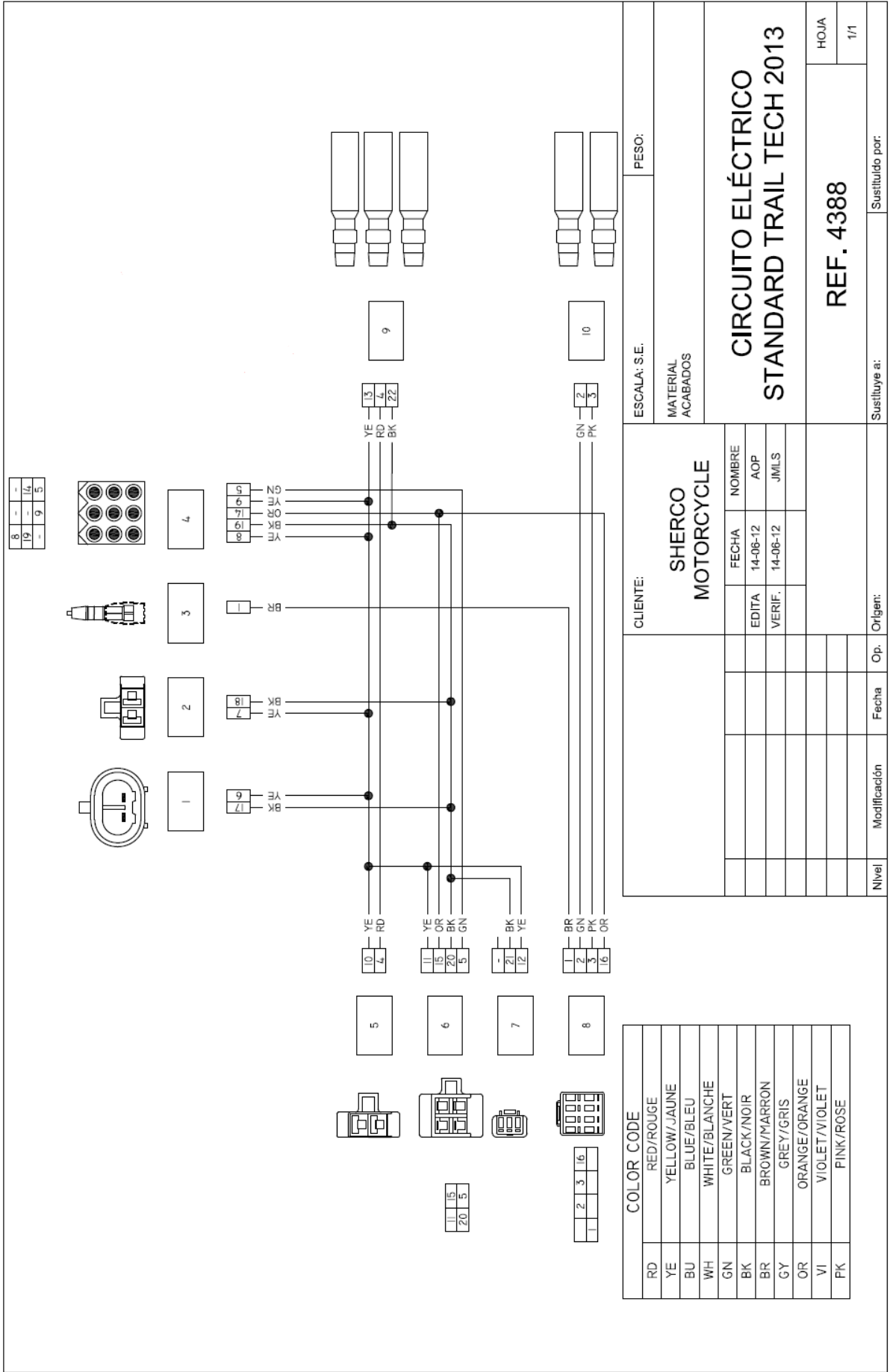

# 250 SEF-R Racing light system cable diagram

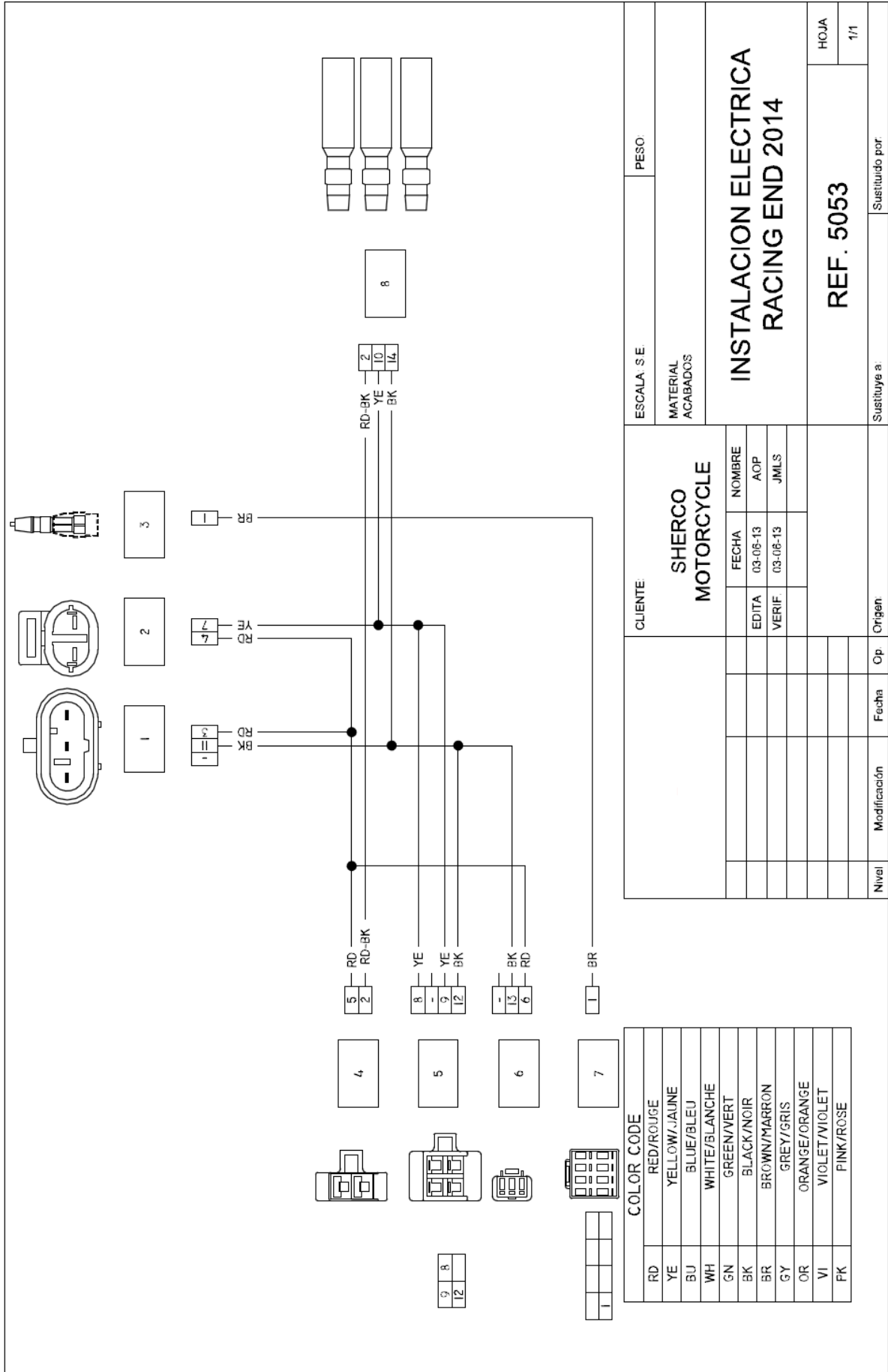

# 300 SEF-R Racing light system cable diagram

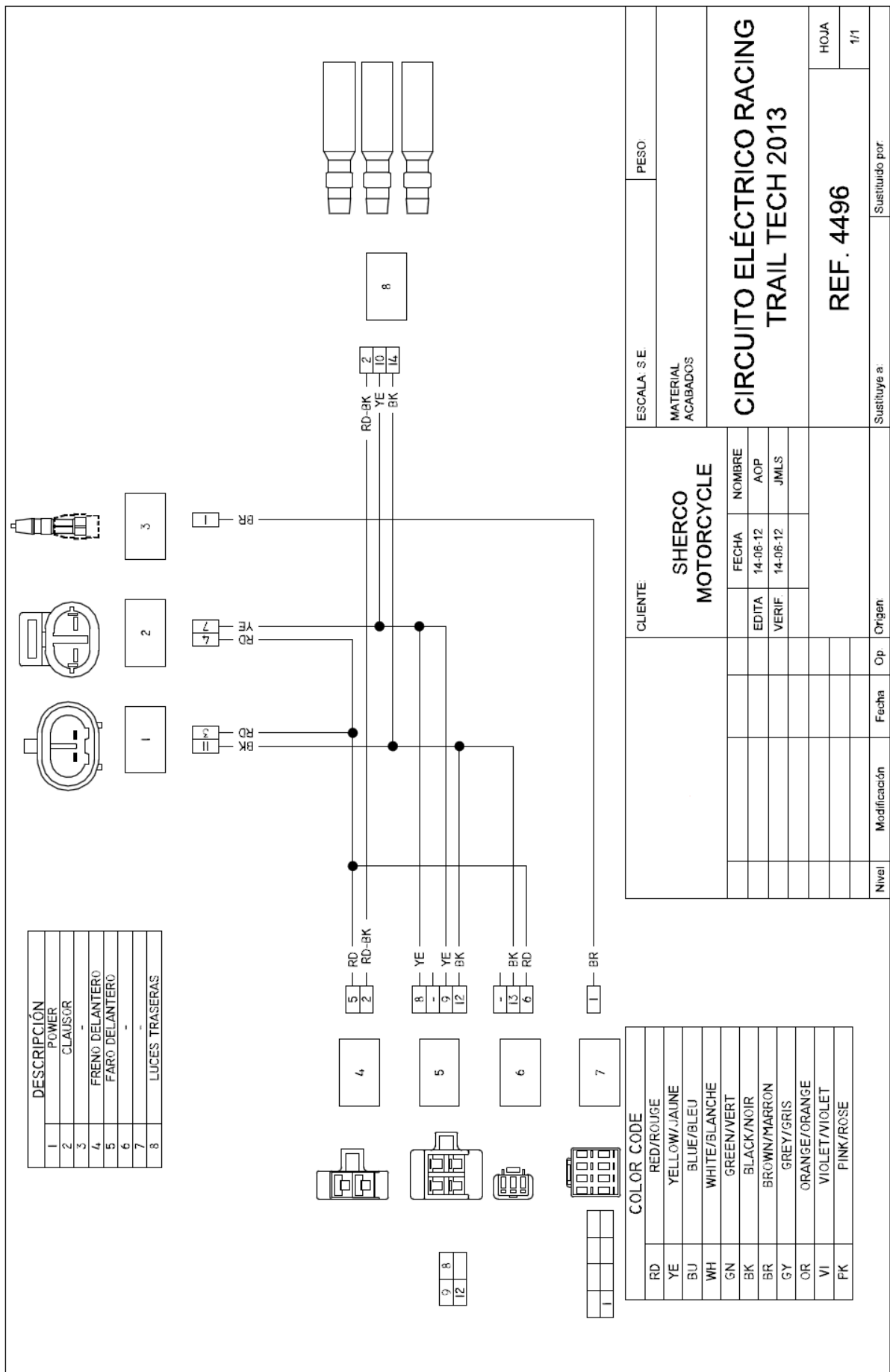

# Flasher installation cable diagram

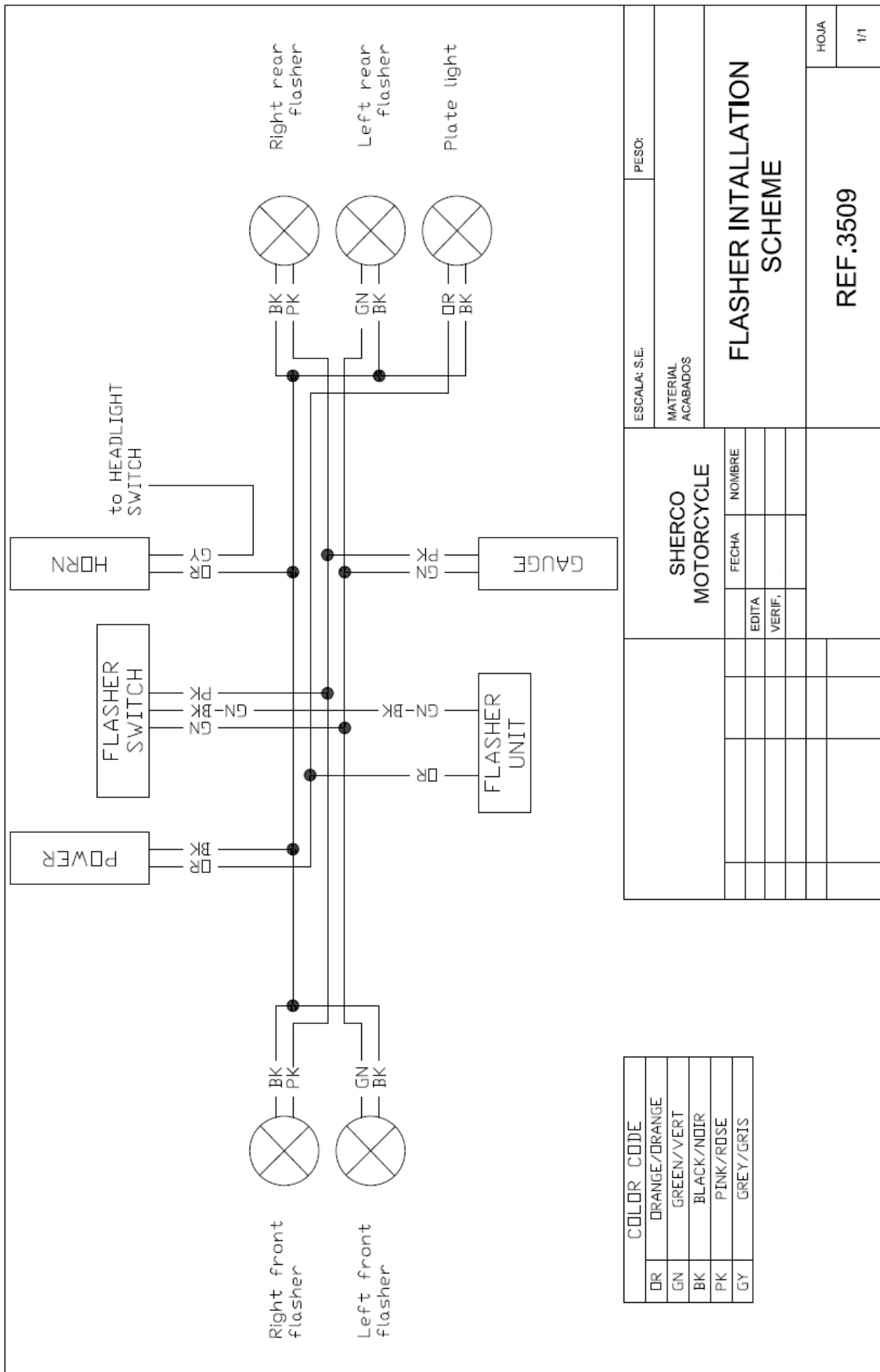

COLOR CODE	
DR	ORANGE/ORANGE
GN	GREEN/VERT
BK	BLACK/NOIR
PK	PINK/ROSE
GY	GREY/GRIS

ESCALA: S.E.		PESO:	
MATERIAL ACABADOS			
<b>FLASHER INTALLATION SCHEME</b>			
SHERCO MOTORCYCLE		FECHA	NOMBRE
EDITA	VERIF.		
<b>REF.3509</b>			
			HOJA
			1/1

# Fan cable diagram

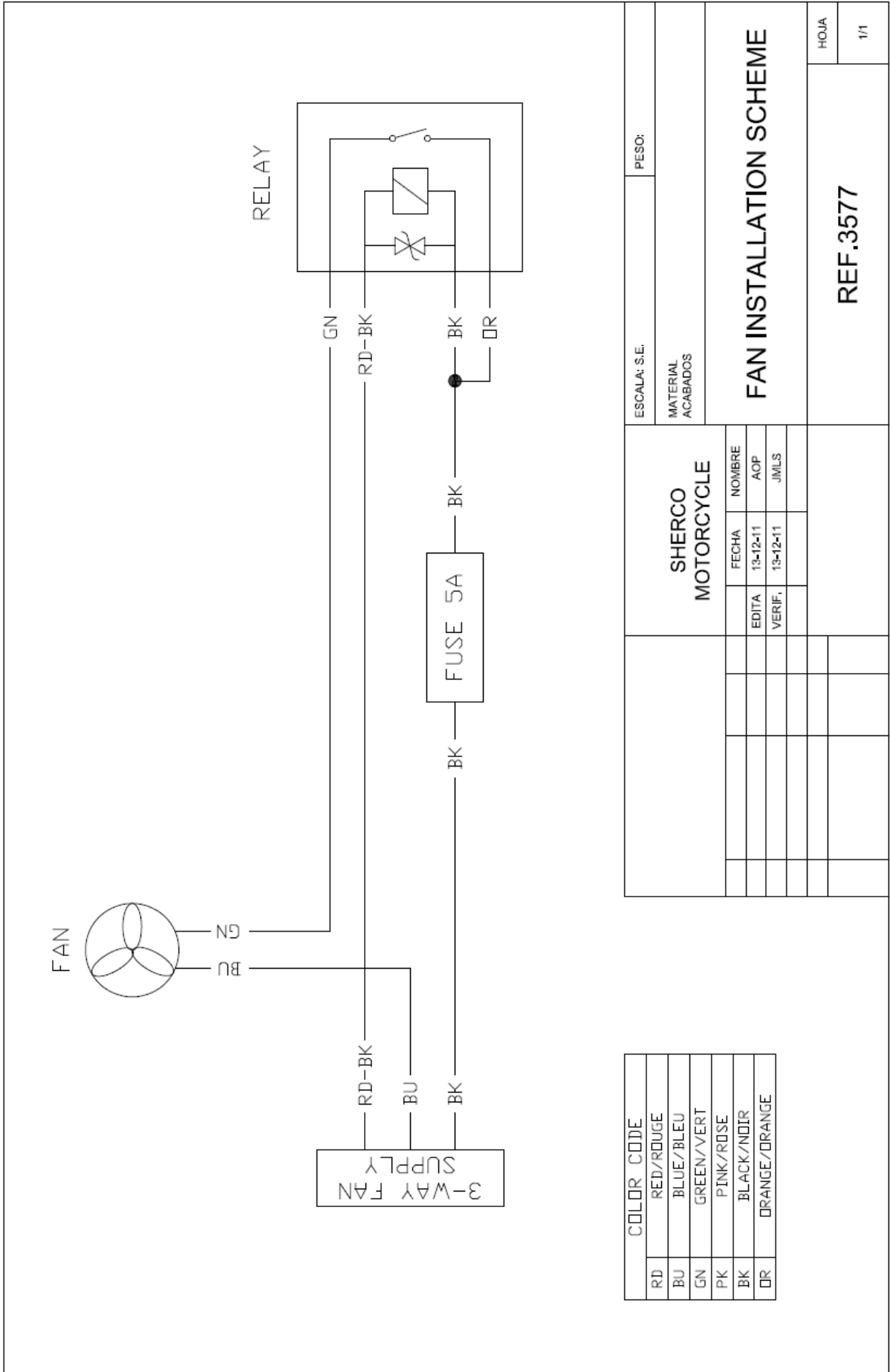

COLOR CODE	
RD	RED/ROUGE
BU	BLUE/BLEU
GN	GREEN/VERT
PK	PINK/ROSE
BK	BLACK/NOIR
DR	ORANGE/DRANGE

SHERCO MOTORCYCLE	
FECHA	NOMBRE
EDITA 13-12-11	AOP
VERIF. 13-12-11	JMLS

ESCALA: S.E.	PESO:
MATERIAL ACABADOS	
<b>FAN INSTALLATION SCHEME</b>	
REF.3577	
HOJA	1/1